

GARANTİ BELGESİ

İMALATÇI FİRMA : YILMAZ MAKİNE SANAYİ VE TİCARET A.Ş
ADRES : TAŞDELEN MAH.ATABEY CADDESİ NO:9 34788 ÇEKMEKÖY
İSTANBUL-TÜRKİYE
TELEFON : 0216.312.28.28 PBX
TELEFAX : 0216.484.42.88
İMZA-KAŞE :

ÜRÜNÜN CİNSİ : SERVO BESLEMELİ ALTTAN ÇIKMA KESME MAKİNESİ
MARKASI : YILMAZ
MODEL KODU : SK 450
BANDROL/SERİ NO :
TESLİM TARİHİ :
GARANTİ SÜRESİ : 2 YIL
AZAMI TAMİR SÜRESİ : 30 İŞ GÜNÜ

YETKİLİ SATICI FİRMA :
ADRES :
TELEFON :
TELEFAX :
İMZA-KAŞE :

CE AB Uygunluk Beyanı

İMALATÇI :

YILMAZ MAKİNE SANAYİ ve TİCARET A.Ş
Taşdelen Mh. Atabey Cd. No9 Cekmeköy-İSTANBUL- TURKIYE

tel: +90 0216 312 2828 fax: +90 0216 484 42 88
yilmaz@yilmazmachine.com.tr

Sorumluluğumuz altında aşağıda bilgileri verilen ürünün;

SK 450 OTOMATİK ALTTAN ÇIKMA DİLİMLEME MAKİNESİ (SERVO KONTROLLÜ)

SERİ NO;

2006/42 AT Makine direktifleri yönetmeliği, 2006/95 EC Alçak gerilim direktifleri yönetmeliği, 2004/108 EC EMC direktifleri yönetmeliği temel gereksinimleri karşıladığını beyan ederiz

Yer Tarih

Yetkili

EC Declaration of Conformity

MANUFACTURER : *YILMAZ MACHINERY INDUSTRY &TRADE CO*
Taşdelen Mh. Atabey Cd. No9 Cekmeköy-ISTANBUL- TURKIYE

tel: +90 0216 312 2828 fax: +90 0216 484 42 88
yilmaz@yilmazmachine.com.tr

Declare on our own responsibility that ;

SK 450 STRAIGHT CUTTING ALUMINIUM SAW (FULL CNC)







SERIAL NO;

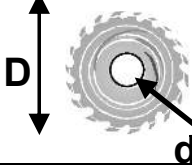

Meets all the provisions of the 2006/42 EC Machinery Directive, 2006/95 EC Low Voltage Directive, and 2004/108 EC EMC Directive which apply to it

Place / Date

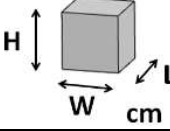
Authorized

TEKNİK ÖZELLİKLER - TECHNICAL FEATURES - ТЕХНИЧЕСКИЕ ОСОБЕННОСТИ

							
SK 450	4 kW 50 -60 Hz 400 V AC 3 P PE	3000 D/dak. RPM	D = 450 mm d = 30-32 mm	6/8 Bar 18 lt / dak. l / min	W = 900 L = 152 H = 142	367 kg	435 kg

 <p>YILMAZ MAKİNE SANAYİ VE TİCARET A.Ş Turgut Özal Bulvarı No:173 Tasdelen 34788 Çekmeköy İSTANBUL-TÜRKİYE Tel: +90 (216) 312 28 28 (Pbx) Fax: +90 (216) 484 42 88 web : www.yilmazmachine.com.tr e-mail: yilmaz@yilmazmachine.com.tr</p> 			
MODEL TYPE MODEL	SK 450	RATED CURRENT NOMİNAL AKIM	11,5 A
SERIAL NO SERİ NO		SAW DIAMETER TESTERE ÇAPI	Ø450xØ30/32mm
PROD.DATE ÜRETİM TAR.		AIR CONSUMP. HAVA TÜKETİMİ	18 Lt/min
TOTAL POWER TOPLAM GÜÇ	5560 W	AIR PRESSURE HAVA BASINCI	6-8 BAR
RATED VOLTAGE NOMİNAL GERİLİM	400V AC 3P PE	WEIGHT AĞIRLIK	367 KG.

BOYUTLAR – DIMENSIONS – РАЗМЕРЫ

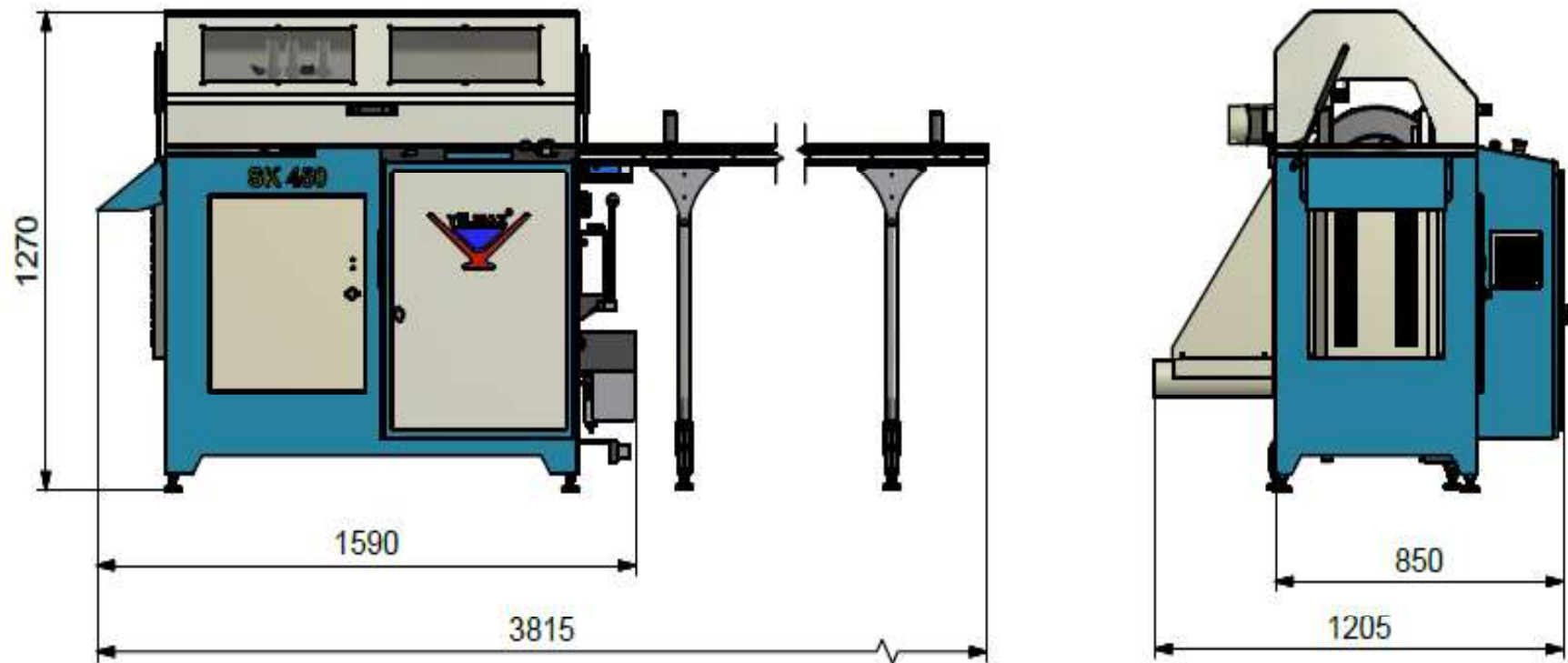

RESİM-FIGURE-РИСУНОК 1

KESME DİYAGRAMI – CUTTING DIAGRAM - ДИАГРАММА РЕЗКИ

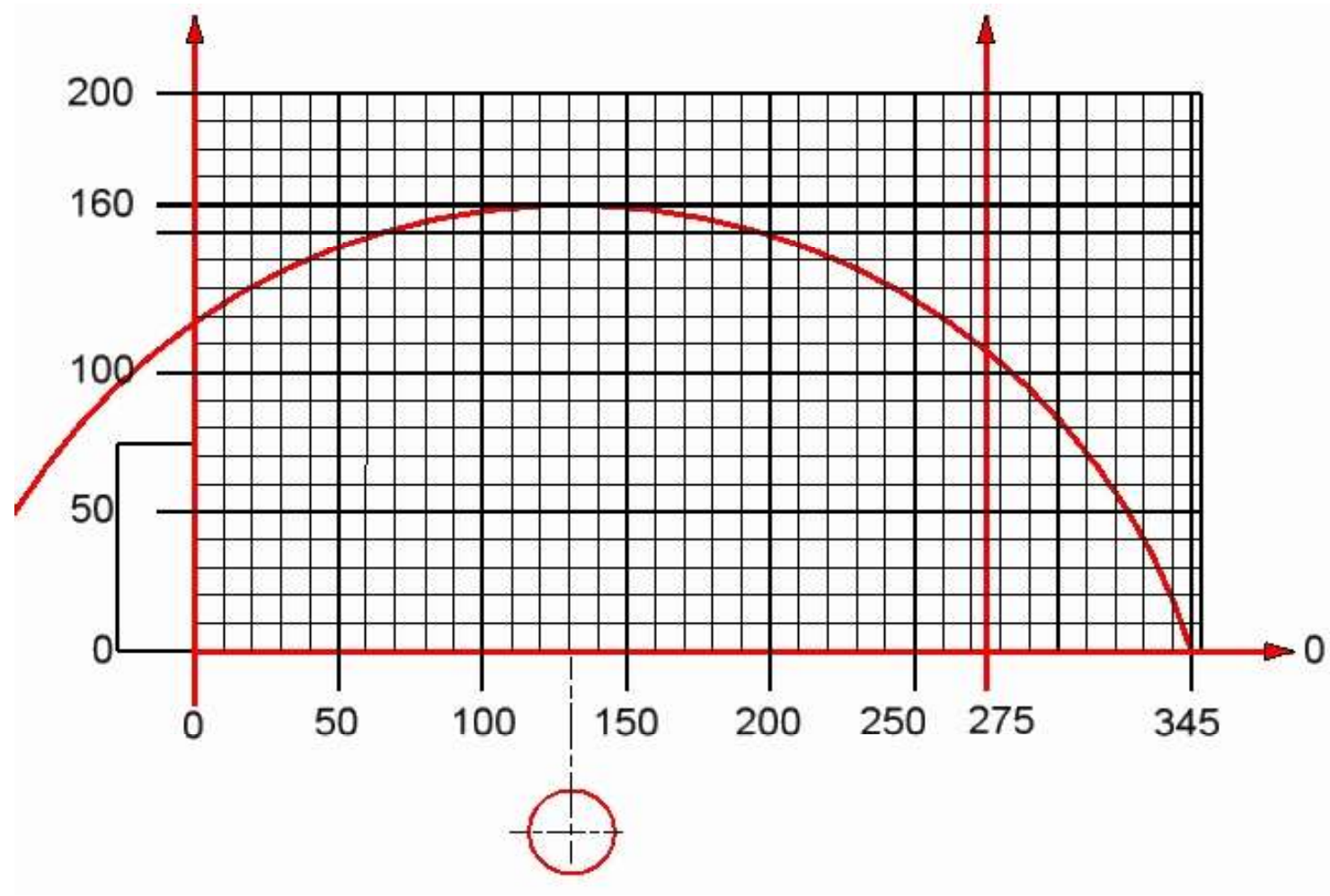

PARÇA LİSTESİ - PART LIST - ПЕРЕЧЕНЬ ДЕТАЛЕЙ

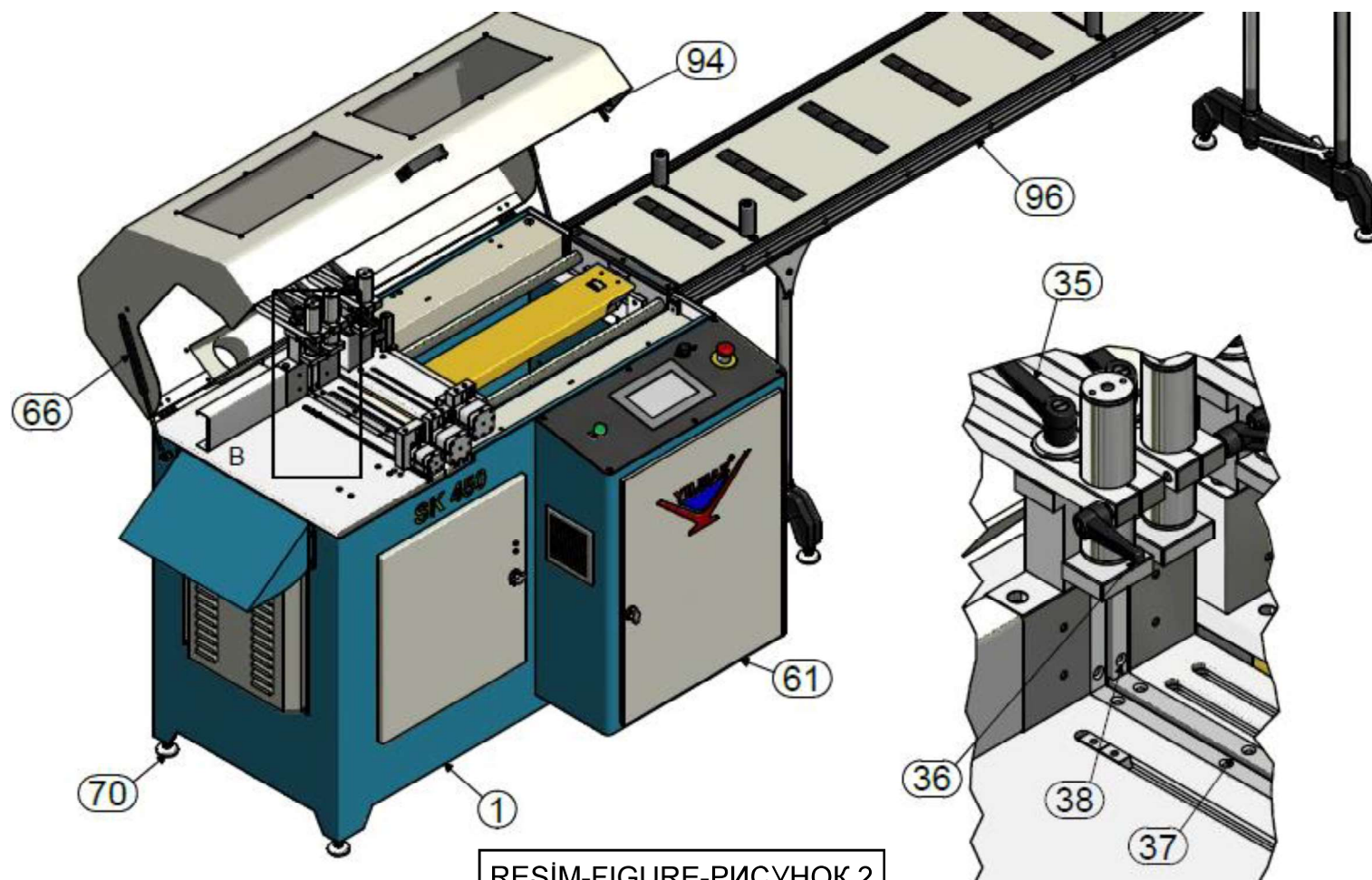

RESİM-FIGURE-PICTURE 2

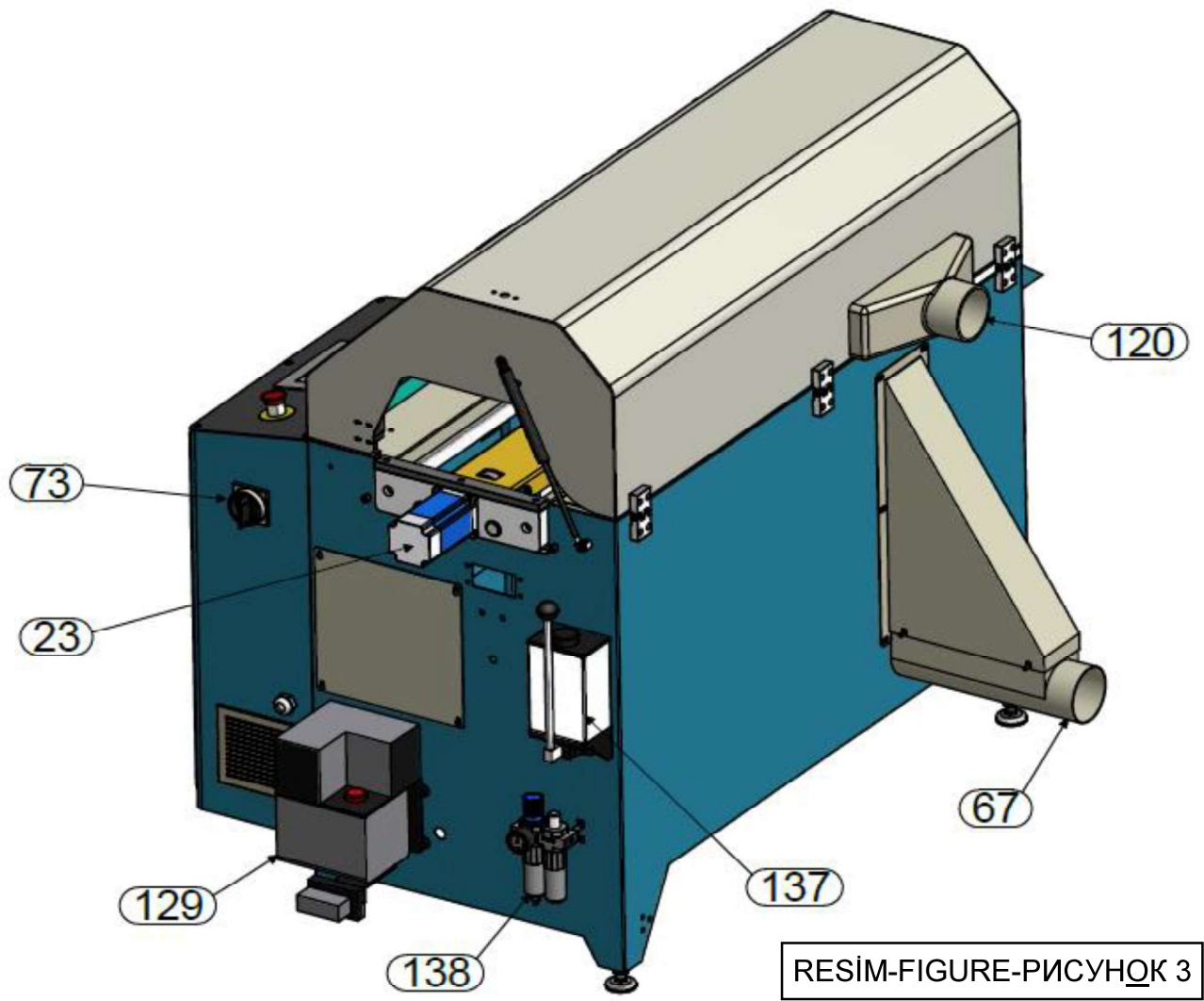

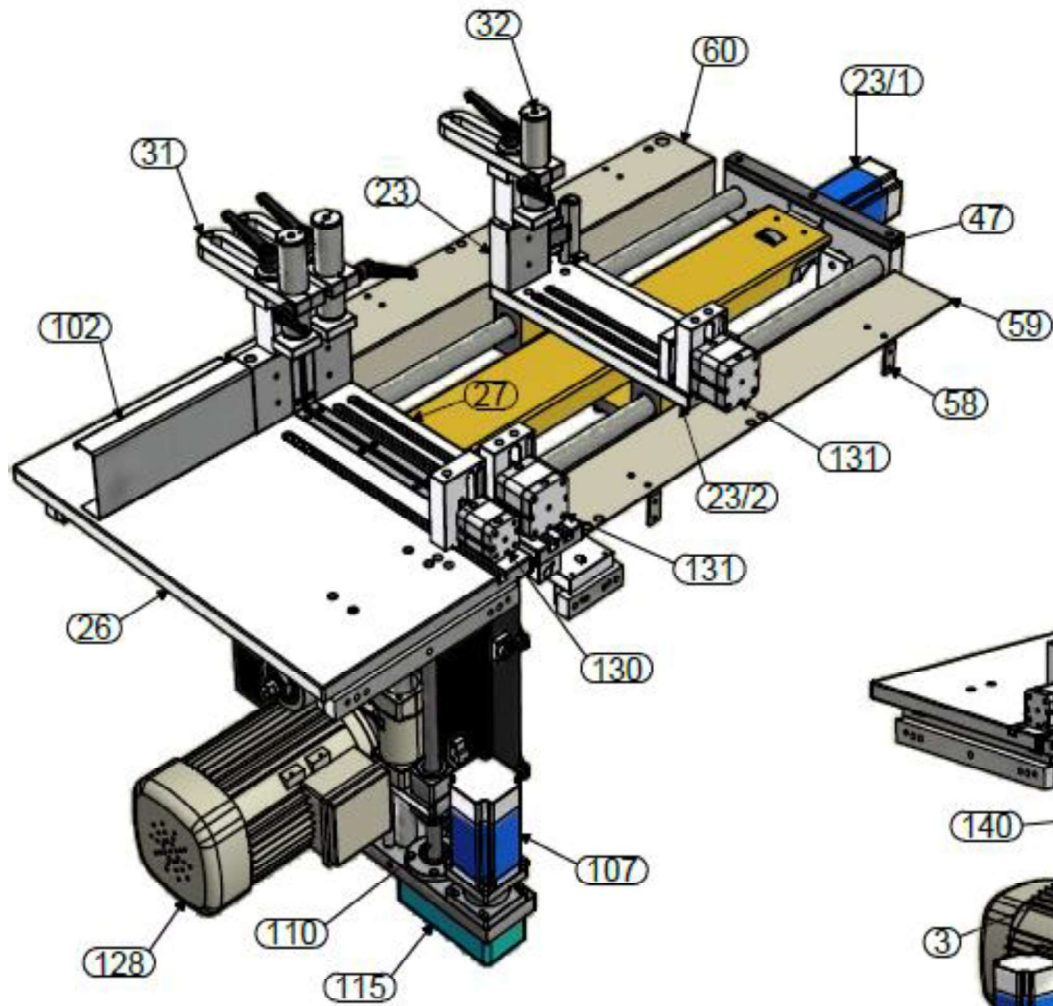

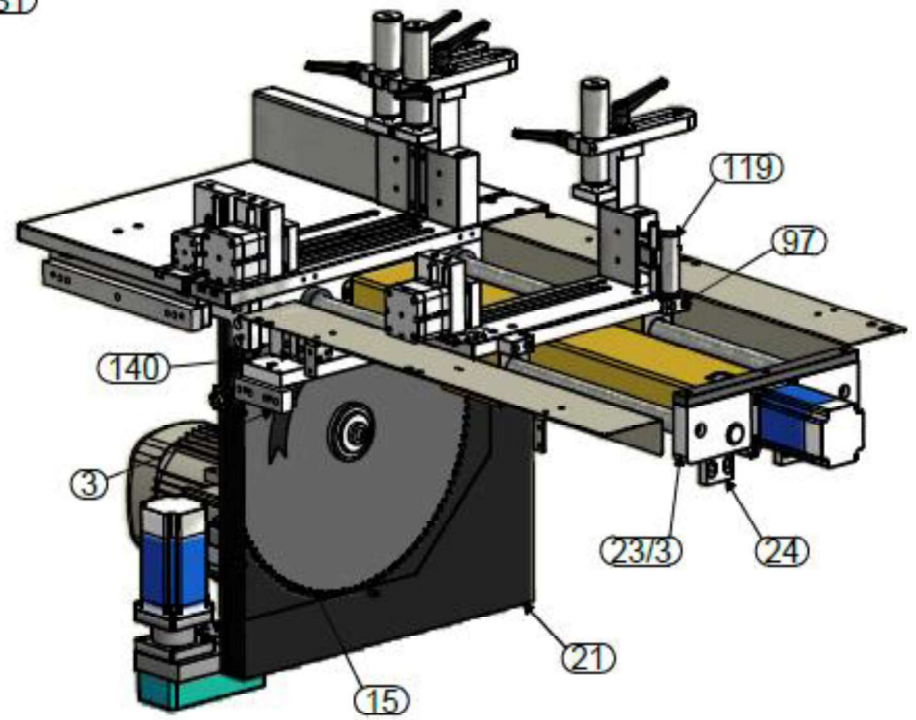

RESİM-Figure-PIÇYHOK 5



NO номер	СТОК КОДУ STOCK CODE ПОРЯДОК КОД	АДЕТ QTY КОЛИЧЕСТВО	NO номер	СТОК КОДУ STOCK CODE ПОРЯДОК КОД	АДЕТ QTY КОЛИЧЕСТВО
1	1SA010000-0049	1	64	1SA030000-0040	1
3	2TU011210-0280	2	67	1SA050000-0112	1
14	2TU011110-0727	1	70	1SC170000-0007	4
15	1SK010000-0034	1	85	2TU011441-0381	2
16	2TU011110-0728	1	89	2TU011210-0294	1
17	2TU011441-0016	1	96	3UA550030-0029	1
18	2TU011110-0488	1	97	2TU012210-0587	2
21	1SA050000-0109	1	102	1SA050000-0125	1
23	2TU011210-0271	1	107	1EL380000-0006	1
23/1	1EL380000-0006	1	110	2TU011110-0699	1
23/2	2TU011410-0053	1	115	2TU012510-0355	1
23/3	2TU012210-0297	1	119	2TU014010-0158	1
24	2TU011210-0265	2	120	2TU012510-0361	1
26	2TU011410-0051	1	128	1EL070001-0005	1
31	2TU011210-0272	3	129	1HD030000-0017	1
47	2TU013210-0032:	1	130	1PN020000-0084	1
58	2TU011441-0248	6	131	1PN020000-0090	2
59	1SA050000-0122	1	137	1HD030000-0003	1
60	1SA050000-0121	1	138	3UA110030-0020	1
61	1SA020000-0018	1	140	1PN020000-0091	2

YEDEK PARÇA LİSTESİ / SPARE PART LIST / СПИСОК ЗАПАСНЫХ ЧАСТЕЙ

PARÇA NO PART NO НОМЕР	RESİM FIGURE РИСУНОК	STOK KODU / CODE ПОРЯДОК КОД	PARÇA ADI – PART NAME НАИМЕНОВАНИЕ ДЕТАЛИ
128		1SR070000-0005	MOTOR KAYIŞI MOTOR BELT
107 / 23-1		1EL380000-0006	SERVO MOTOR
		2TU012110-0129	SERVO KAPLIN
110		2TU011110-0699	VİDALI MİL (KESME GRUBU) LINEAR

		2TU011110-1273	VİDALI MİL (SÜRÜCÜ GRUBU) LİNEAR
94		1EL020000-0025	ÜST KAPAK GÜVENLİK SWITCHİ
66		1YY030000-0009	AMORTİSÖR
		1PL010000-0022	VİDALI MİL KÖRÜĞÜ
36		3UA040030-0005	M8*45 PİPO M8*45 HANDLE

35		3UA040030-0002	M10*50 PİPO M10*50 HANDLE
37		2TU012210-0353	TABLA KANAL LAMASI 1
38		2TU012210-0354	TABLA KANAL LAMASI 2
128		1EL070001-0005 400V-415V (3P 50 Hz)	MOTOR MOTOR
15		1SK010000-0025	Ø 550 TESTERE Ø 550 SAW

CONTENTS

- 1. General information**
 - 1.1. Introduction
 - 1.2. Service Information
- 2. Safety**
 - 2.1. Safety Symbols and Their Meanings
 - 2.2. Accidents Prevention
 - 2.3. General Safety Information
- 3. Machine's Description**
- 4. Transport of the Machine**
- 5. Installation of the Machine**
 - 5.1. Preparation
 - 5.2. Connecting to Power Source
- 6. Machine's Safety Information**
- 7. Operation**
 - 7.1 Preparation
 - 7.2 Operation
- 8. Maintenance, Service and Repair**
 - 8.1 Maintenance
 - 8.2 Lubrication of the moving unit
 - 8.3 Changing the cutting tool
 - 8.4 Replacing the Motor Belt
 - 8.5 Adjust the air pressure
- 9. Noisy emission values**
- 10. Warranty conditions**

1. GENERAL INFORMATION

1.1. Introduction

The user's manual given by the manufacturer contains necessary information about the machine parts. Each machine operator should read these instructions carefully, and the machine should be operated after fully understanding them.

Safe and efficient use of the machine for long term depends on understanding and following the instructions contained in this manual. The technical drawings and details contained in this manual constitute a guide for the operator.

1.2. Service Information

In case of any technical problem please contact your nearest YILMAZ dealer, or YILMAZ head office through the above mentioned phone, fax or e-mail address.

Technical labels with the model description of the machine are fixed onto the front side of each machine.

The machine's serial number and manufacturing year are stipulated on the technical label.

Average life usage of production is 10 years. If you have any further failure and complaint, please inform to our below mentioned technical service by verbal or written

AUTHORIZED TECHNICAL SERVICE CENTER ADDRESS

TAŞDELEN MH. ATABEY CD. No 9 34788 ÇEKMEKÖY – İSTANBUL / TÜRKİYE

Tel 0216 312 28 28 Pbx.

Fax 0216 484 42 88

E-mail service@yilmazmachine.com.tr













Web www.yilmazmachine.com.tr

For minimize the documantation, It is very necessary to mention below details at the agreements signed with suppliers and dealers of the purchased machines

- | | |
|------------------------------------|--|
| • Machine model | • Voltage and frequency |
| • Machine's serial number | • Date of purchase |
| • Description of the machine fault | • Name of dealer where machine was purchased |
| • Average daily operation period | • Sending the or video of the machine part which creates problem |

2. SAFETY

2.1. Safety Symbols and Their Meanings

	Read the user guide		Ensure safe working position, always keep your balance.
	Wear ear protectors		Elektrical excitation
	Wear safety goggles		Don't place your hands between parts in motion..
	If the power cable should be damaged during operation, don't touch and unplug it. Never use damaged power cables.		High temperature warning
	During saw blade change operations, use protective gloves		Keep your fingers clear of the movable parts of the glide arm.
	The above symbol DANGER WARNING , warns you against specific dangers, and you have definitely to read them..		The IMPORTANT symbol above is one telling to apply special care and to be careful at carrying out the specified operation

2.2. Accidents Prevention



- 2.2.1 Our machines are manufactured in accordance with CE safety directives, which cover national and international safety directives.
- 2.2.2 It is the task of the employer to warn his staff against accident risks, to train them on prevention of accidents, to provide for necessary safety equipment and devices for the operator's safety.
- 2.2.3 It is the task of the employer to warn his staff against accident risks, to train them on prevention of accidents, to provide for necessary safety equipment and devices for the operator's safety.
- 2.2.4 Machine should be operated only by staff members, who have read and understood the contents of this manual.
- 2.2.5 All directives, recommendations and general safety rules contained in this manual have to be observed fully. The machine cannot be operated in any way for purposes other than those described herein. Otherwise, the manufacturer shall not be deemed responsible for any damages or injuries. And such circumstances would lead to the termination of the warranty

2.3. General Safety Information

- 2.3.1 The power cable should be led in such a way that nobody can step on it or nothing can be placed on it. Special care has to be taken regarding the inlet and outlet sockets
- 2.3.2 Don't overload machines for drilling and cutting. Your machine will operate more safely with power supply in accordance with the stipulated values.
- 2.3.3 Use correct illumination for the safety of the operator. (ISO 8995-89 Standard The lighting of indoor work system)

- 2.3.4** Use correct illumination for the safety of the operator. (ISO 8995-89 Standard The lighting of indoor work system)
- 2.3.5** Don't use any materials other than those recommended by the manufacturer for cutting operations on the machine.
- 2.3.6** Ensure that the work piece is clamped appropriately by the machine's clamp or vice
- 2.3.7** Ensure safe working position, always keep your balance.
- 2.3.8** Keep your machine always clean for safe operation. Follow the instructions at maintenance and replacement of accessories. Check the plug and cable regularly. If damaged, let it replace by a qualified electrician. Keep handles and grips free of any oil and grease.
- 2.3.9** Unplug first, before conducting and maintenance works.
- 2.3.10** Ensure that any keys or adjustment tools have been removed before operating the machine..
- 2.3.11** If you are required to operate the machine outside, use only appropriate extension cables.
- 2.3.12** Repairs should be carried out by qualified technicians only. Otherwise, accidents may occur.
- 2.3.13** Before starting a new operation, check the appropriate function of protective devices and tools, ensure that they work properly. All conditions have to be fulfilled in order to ensure proper operation of your machine. Damaged protective parts and equipment have to be replaced or repaired properly (by the manufacturer or dealer).
- 2.3.14** Don't use machines with improper functioning buttons and switches
- 2.3.15** Don't keep flammable, combustive liquids and materials next to the machine and electric connections.

3. MACHINE'S DESCRIPTION

Ø450 mm Automatic Feed & Cut Mitre Saw for efficient cutting of Aluminum, hard plastic and non ferrous materials

- Fast cutting advancement is a servo-driven system.
- Saws with different diameters can be used (max. saw diameter: 450 mm)
- Material feed advancement (material movement) is a servo-driven system
- Stroke of feeder is adjustable from 5 - 600 mm. Multiple stroke adjustment is possible up to a maximum length of 9990 mm.
- Accuracy is ± 0.1 mm.
- PLC software controlled working process. Capable of memory storage of previous job specifications
- Digital display for minimum wastage
- Over head safety guarding for the operator
- Air pressure drop sensor
- Saw complies with CE Safety Directives

STANDART AKSESUARLAR	OPSiYONEL AKSESUARLAR
Conveyor	Additional 450 mm saw blade
Ø 450 mm Saw Blade	
Cooling system	
Lubrication system	
User's manual	

4. TRANSPORT OF THE MACHINE

IMPORTANT

4.1. The transport should be done by qualified personnel only.

- 4.2. The machine should be transported by lifting with proper equipment (not touching the ground during the transport).
- 4.3. Unless customer requests the contrary, the machine will be delivered with wooden packaging.
- 4.4. Movable parts on the machine should be fixed before carrying out the transport.
- 4.5. The machine size and weight measurements, given the technical specification sheet.

5. INSTALLATION OF THE MACHINE

5.1 Preparation

- 5.1.1 The machine size and weight measurements, given the technical specification sheet. The ground, where the machine will be placed, should be even, solid enough to bear the weight of the machine
- 5.1.2 The machine should be located approx. 100 cm away from the rear wall
- 5.1.3 Remove shipping bar (FIGURE 6).
- 5.1.4 Level the machine by using a water gauge, placed on its upper surface, and adjusting the feet (FIGURE 7).

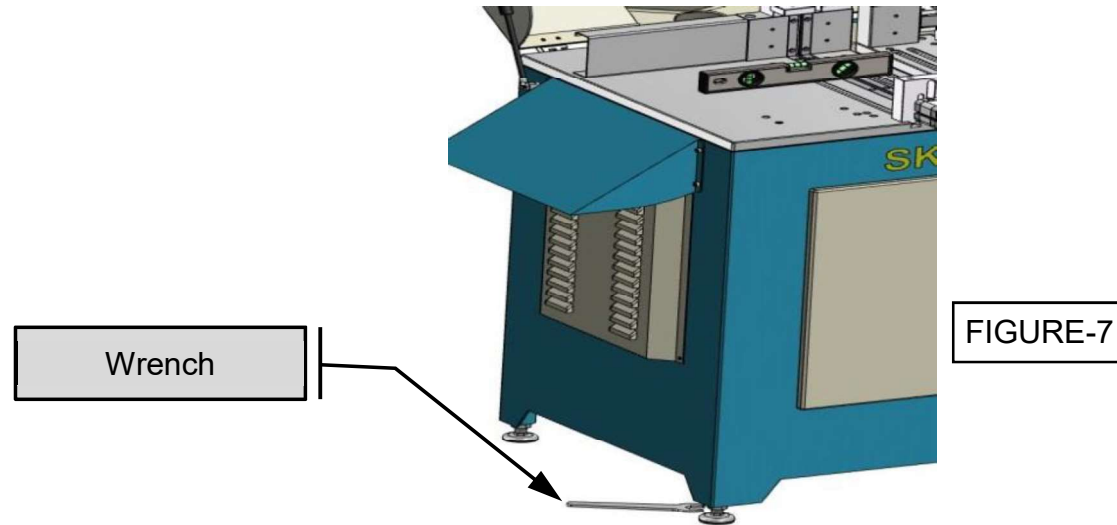

5.1.5 Backside chip removal manifold (lower and upper), which is a suction system having an inner and outer diameter of 97 and 100 mm, respectively, are installed before shipment. In case chips are not removed by suction system, do not use manifold connecting pipe (FIGURE 9).

5.1.6 Install the backside chip removal manifolds, at the outlet of the saw, as shown in figure (FIGURE 8).



FIGURE- 8



5.1.7 When using saw dust collecting manifold, dust collecting speed (flow rate of discharge air) should be assumed 20 m/s for dry saw dust. For saw dusts (humidity is equal or greater than 18%) flow rate of discharge air should be minimum 28 m/s.

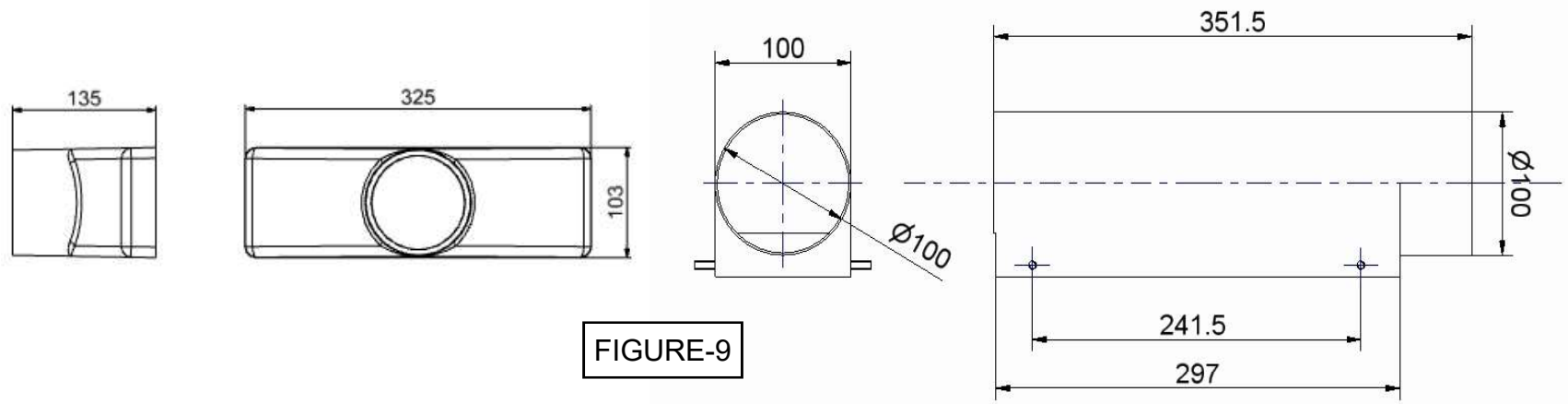

5.1.8 Install the part that allows the removal of processed pieces on the left hand side of machine (FIGURE 10).



5.1.9 Place chip removal tray under the machine as shown in figure (FIGURE 11).



FIGURE 11

5.1.10 **INSTALLATION OF CONVEYOR**

- Fix 4 pieces of conveyor standing mil on to feet by using nuts (FIGURE 12).

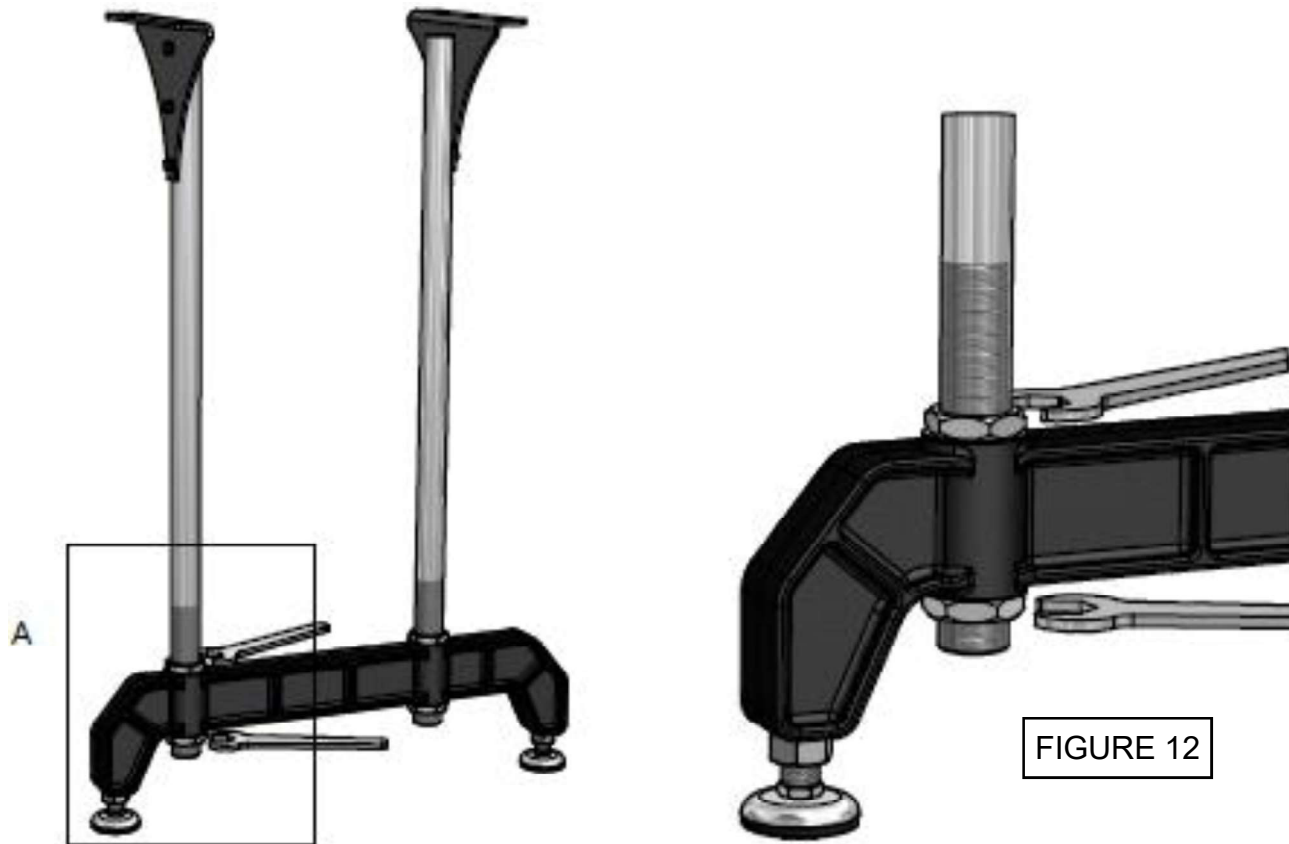

- Fix foot assembly on to bolts at the channel, which is located under the conveyor profile, by using nuts (FIGURE 13).

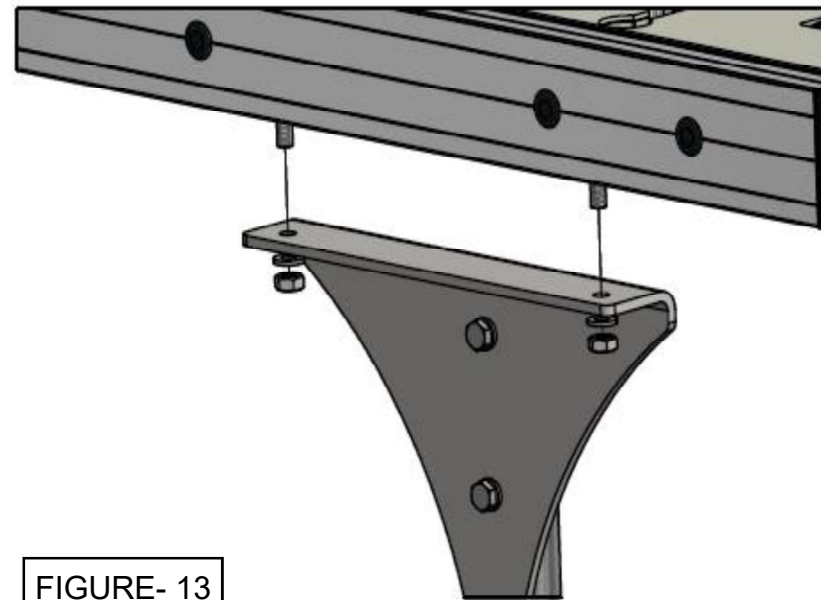

FIGURE- 13

- Mount the upper support of conveyor with the help of imbus bolts as shown in figure (FIGURE 14).

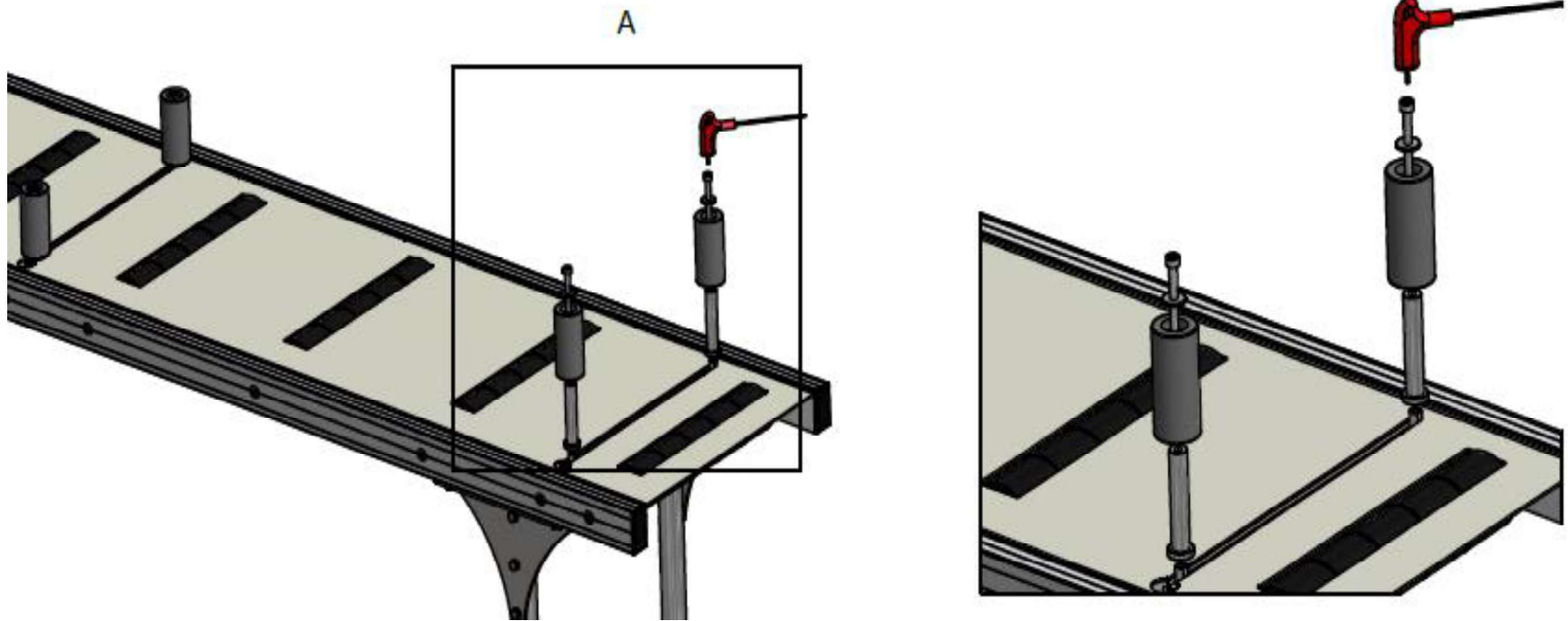

FIGURE 14

- After assembling, mount conveyor on to chassis, which is at the right side of machine, using the nuts placed on the machine as shown in figure (FIGURE 15).

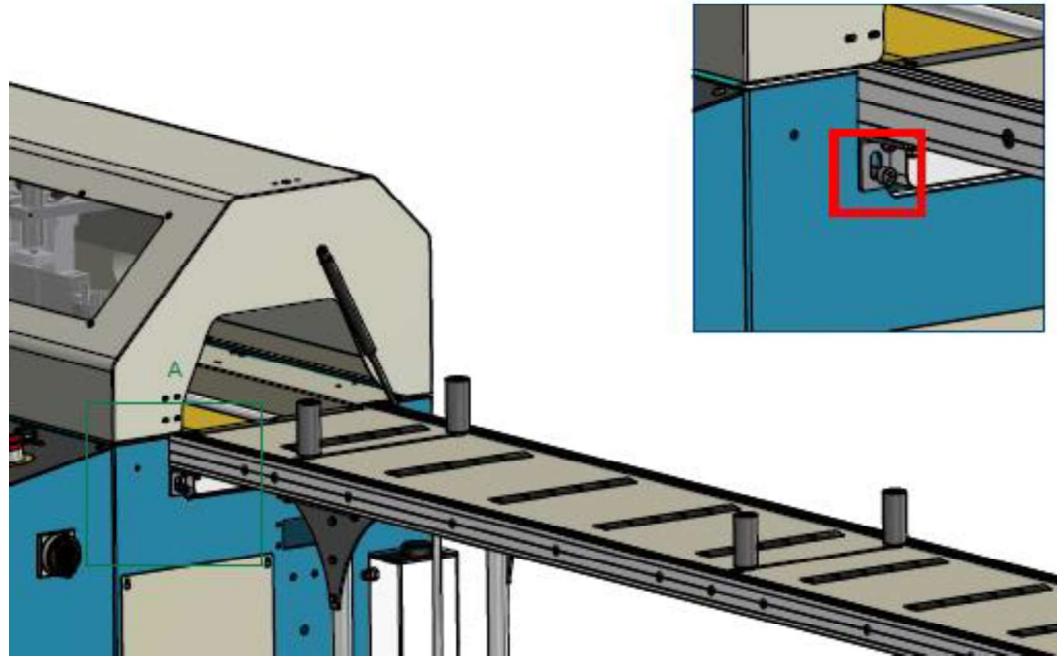

FIGURE 15

5.2 Connecting to Power Source

- 5.2.1 The Electrical connection must be made by a licensed electrician
- 5.2.2 The power outlet socket on the machine should be available.
- 5.2.3 Plug the machine to a grounded socket.

5.2.4 Main voltage of the machine is optional as 230 V 50 Hz or 400 V 50 Hz.



5.2.5 Check the power source voltage. It has to be in accordance with the values stipulated on the machine's type label

5.2.6 After electrical connection is made, machine must be operated in idle running and it must be controlled whether rotation directions of cutting tools are correct or not and if the rotation direction is wrong, appropriate connection must be made.

6. MACHINE SAFETY INFORMATION

6.1 Lifting, installation, electric maintenance of the machine should be carried out by qualified personnel only.

6.2 Routine maintenance and scheduled maintenance should be carried out by qualified personnel after unplugging the machine and disconnecting the air supply first.

6.3 Ensure that the machine has been cleaned, tested and maintain before starting to operate.

6.4 Check the safety devices, power cable and moving parts regularly. Don't operate the machine before having replaced defective safety devices or faulty parts.

6.5 Never replace the milling cutters before unplugging first.



6.6 Keep foreign materials away from the working area of the machine, keep away from the machine's moving parts

6.7 Do not work on the machine by removing the protective parts



6.8 Do not put your hand close to the saw when the machine is in operation.



The safety data have been defined above. In order to prevent physical damage or damage to the equipment, please read the safety information carefully and keep the manual always in an easy accessible place.

7. OPERATION

7.1 Preparation

7.1.1 Degrease and dry the machine table. Especially ensure that the holding grips and handles are clean and dry



7.1.2 Clean all surfaces of the machine from chip and foreign particles. Use eye glasses for protection.

7.1.3 Control whether cutting tools (FIGURE 6 NO: 15) are inserted safely to their places.

7.1.4 Control cutting tools against corrosion, distortion and fractions. If cutting tools are damaged, change them.

7.1.5 Cutting tool must process on the part after machine is operated and cycled.

7.1.6 **Do not process the profile before clamping the work piece properly.**

7.1.7 In order to adjust forward movement speed of the saw please refer to page Safe Using of Program Terminal

7.2 Operation

7.2.1 Utilization of Operator Panel

7.2.1.1 Turn the main power switch to position “1”. Program starts automatically

7.2.1.2 Press on  in the appeared screen in order to send the tool to reference position (FIGURE 16).

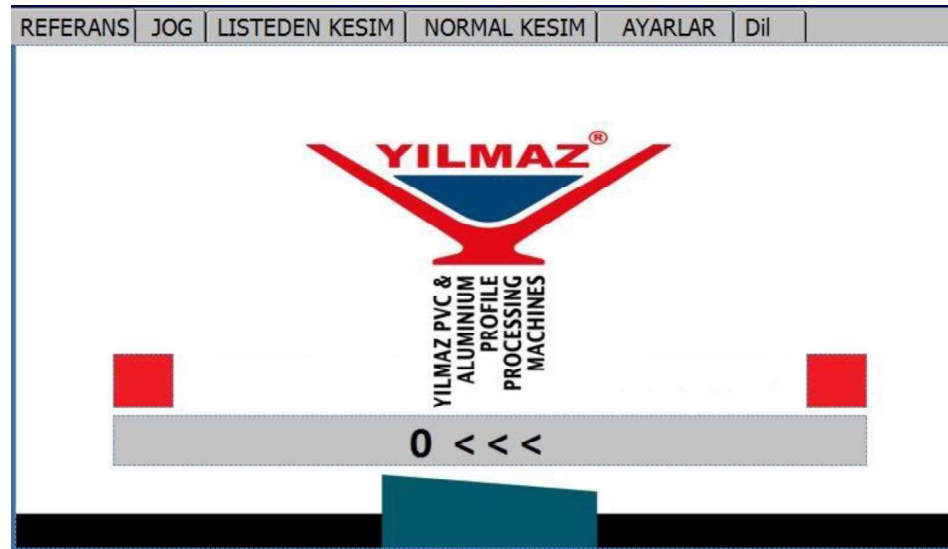

FIGURE 16

7.2.1.3 User interface language can be selected on LANGUAGE tab. Language of screen changes automatically (FIGURE 17)

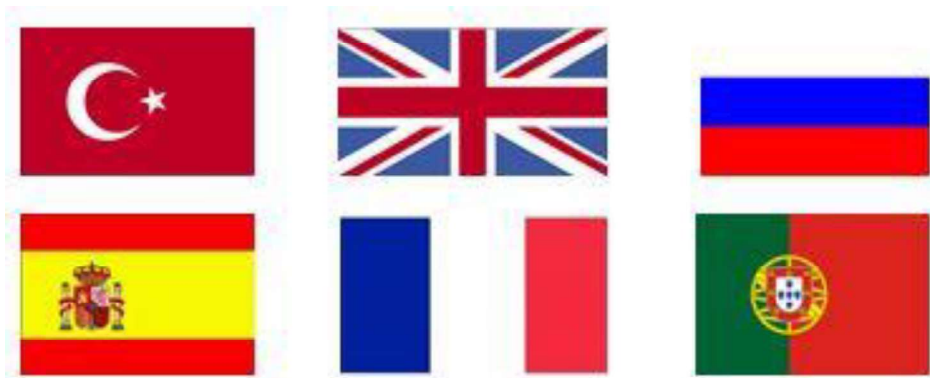

FIGURE- 17



FIGURE 18



7.2.1.4 After reference determination is completed, the lights next to button turn on

7.2.1.5 Having completed the reference determination, machine is ready for cutting.

7.2.2 Standard Cutting Operation

7.2.2.1 Press on **Normal Cut** tab (FIGURE 19)

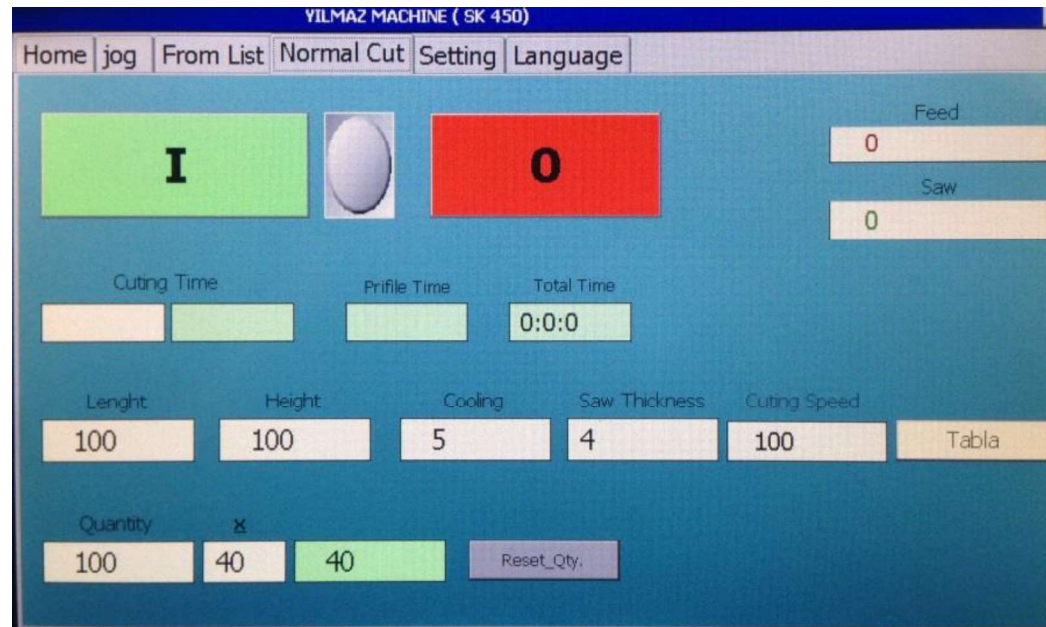





FIGURE- 19

7.2.2.2 Enter length of piece to be cut into  section.

7.2.2.3 Enter the height that saw reaches during cutting operation into  section (For example if the height of piece to be cut is 50 mm, enter 70 mm into the height area).

7.2.2.4 Enter the number of pieces to be cut into section.

7.2.2.5 After the machine completes cutting, number of processed pieces automatically increases by the amount displayed in  section. Increment is same as the number written in group section. For instance if 3 is entered as the amount of group, counter increases by 3, such that 3, 6, 9, 12, ...

7.2.2.6 In case parts are cut together as a group, enter the number of pieces in one group to  (For example if there are 3 pieces in each group, enter 3).

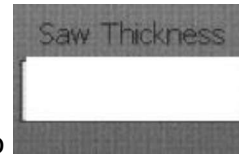

7.2.2.7 Enter the width of saw on the machine into section.



7.2.2.8 In case cooling water is used during cutting, enter the frequency of operation in section.

7.2.2.9 After completing the cutting operation, saw returns back to its starting position, and release the sides of

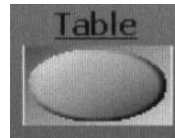

table automatically, then press on button in order to bring the table at its starting position (Active operation of table results in longer operating life for saw and cleaner material surface).

7.2.2.10 After all dimension and values are entered, place part.

7.2.2.11 Squeeze the clamps

7.2.2.12 Close upper cover (Door of the saw changing cabin should also be closed).



7.2.2.13 Press on button to start cutting operation

7.2.2.14 Machine cuts automatically. Operation finishes when either the entire entered amount to be cut is processed or machine runs out of parts.

7.2.2.15 In case operation is needed to be stopped before regular completion time, press on

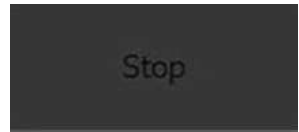

button. If this button is pressed during cutting, machine completes the current cutting operation and stops after retrieval.

7.2.2.16 If operation is needed to be stopped immediately, use emergency stop button

7.2.3 Listeden Kesim Operasyonu

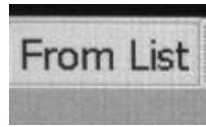

7.2.3.1 Press on button to switch on automatic cutting (list dependent) screen (FIGURE 20).

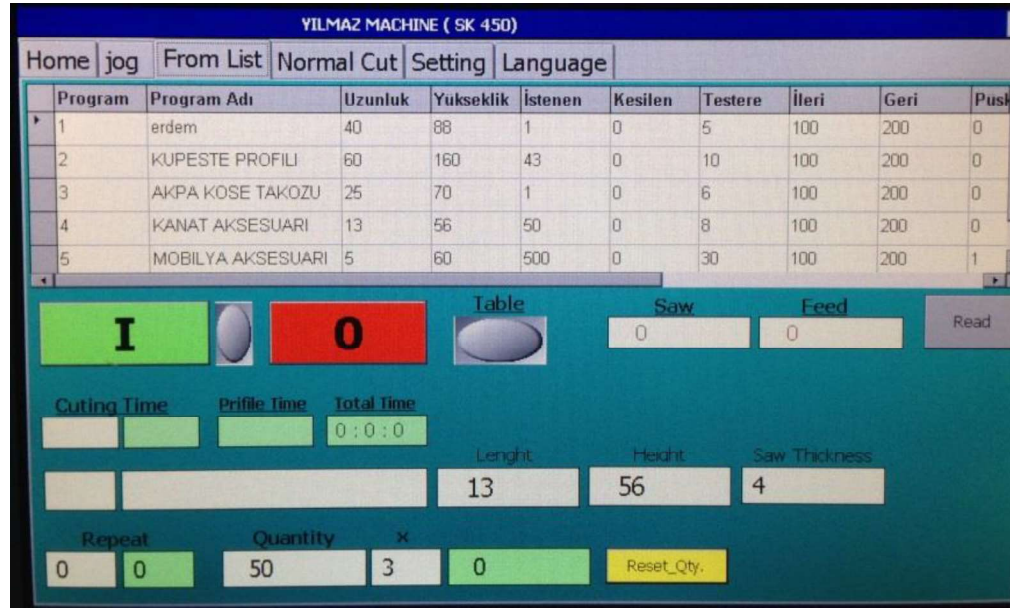

FIGURE- 20

7.2.3.2 Define the status of profiles as active or passive in cutting list (**See creating recipe section**).

7.2.3.3 Enter the recurrence of cutting process for selected parts in the cutting list into the white section



7.2.3.4 If table is defined as active in cutting list, the  button lights in green. Table should be defined as active or passive in the cutting list.

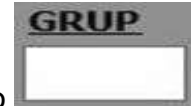

7.2.3.5 Enter the number of elements in a group into  section, which is mounted for cutting.

7.2.3.6 The rest of the required values provided by cutting list.

7.2.3.7 Mount the part after completing all necessary selections

7.2.3.8 Squeeze the clamps

7.2.3.9 Close covers

7.2.3.10 Choose the initial program at which cutting operation starts **(For example prescription number 1)**.

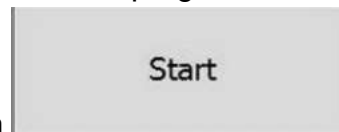

7.2.3.11 Press on  button to initiate cutting process

7.2.3.12 During cutting process, if the number of parts to be cut is completed for cutting list 1, machine starts to process the items in cutting list 2, automatically. In short, when the all the parts in any list is processed, operation continues with the next list..

7.2.3.13 Machine stops operation when there remains no part to be cut. When new part is mounted and operation is started, machine continues to its operation at which it stops

7.2.4 General Information on Standard Slicing and Automatic Cutting

7.2.4.1 The duration of cutting process, total cutting duration for a profile, and the total duration for all profiles

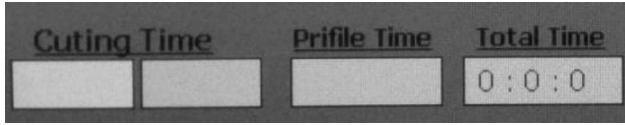
is shown in  sections.

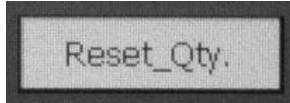
7.2.4.2 The number of processed parts is reset by pressing on  button.

7.2.4.3 Machine holds a saw whose diameter is 450 mm. Saws with smaller diameter can be mounted on the machine. In case a saw having smaller diameter is mounted, half of the diameter difference between the current one should be entered as offset value in screen **(For instance if the replaced saw has a diameter of 400 mm, 25 mm should be entered as offset value.)**

7.2.5 Creating Cutting List and Uploading to Machine

Open a new excel file

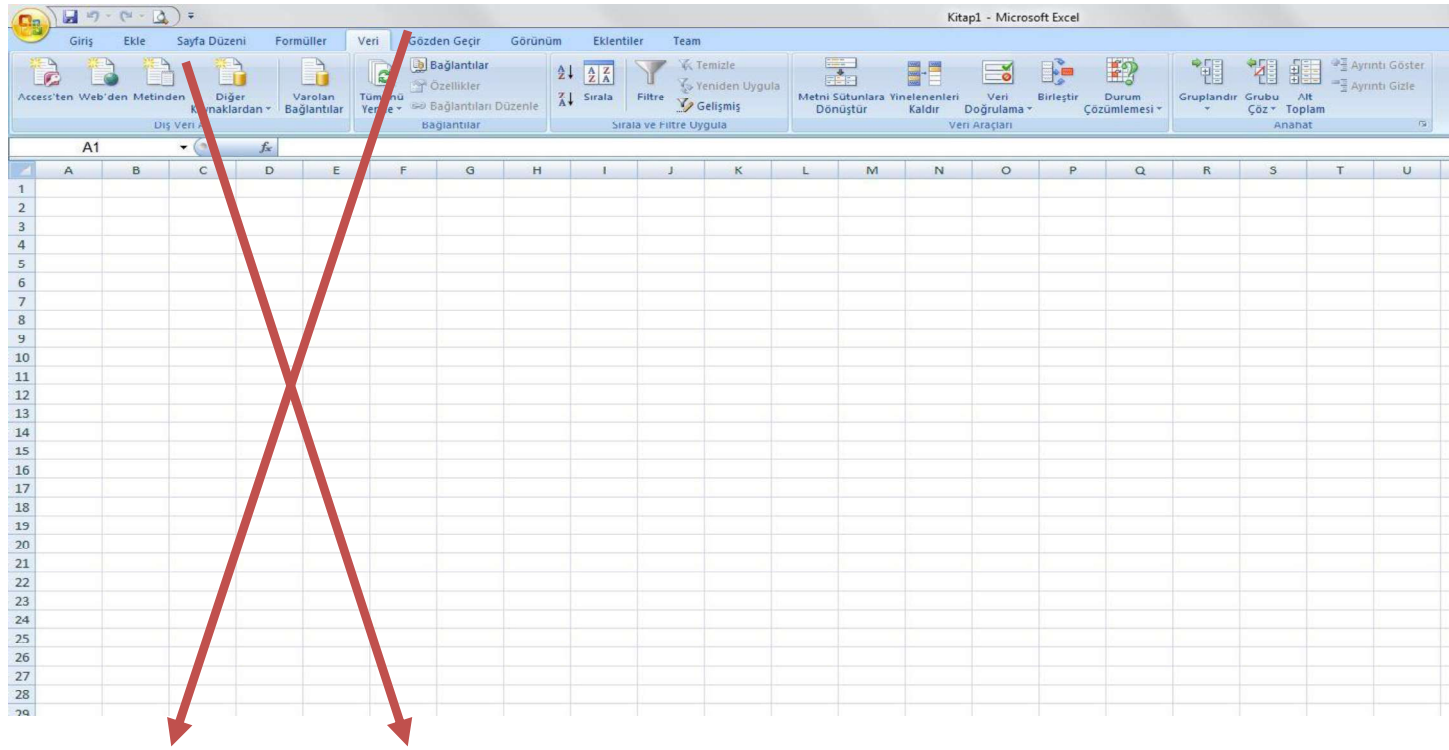

Push on 'Data and From text' keys respectively.

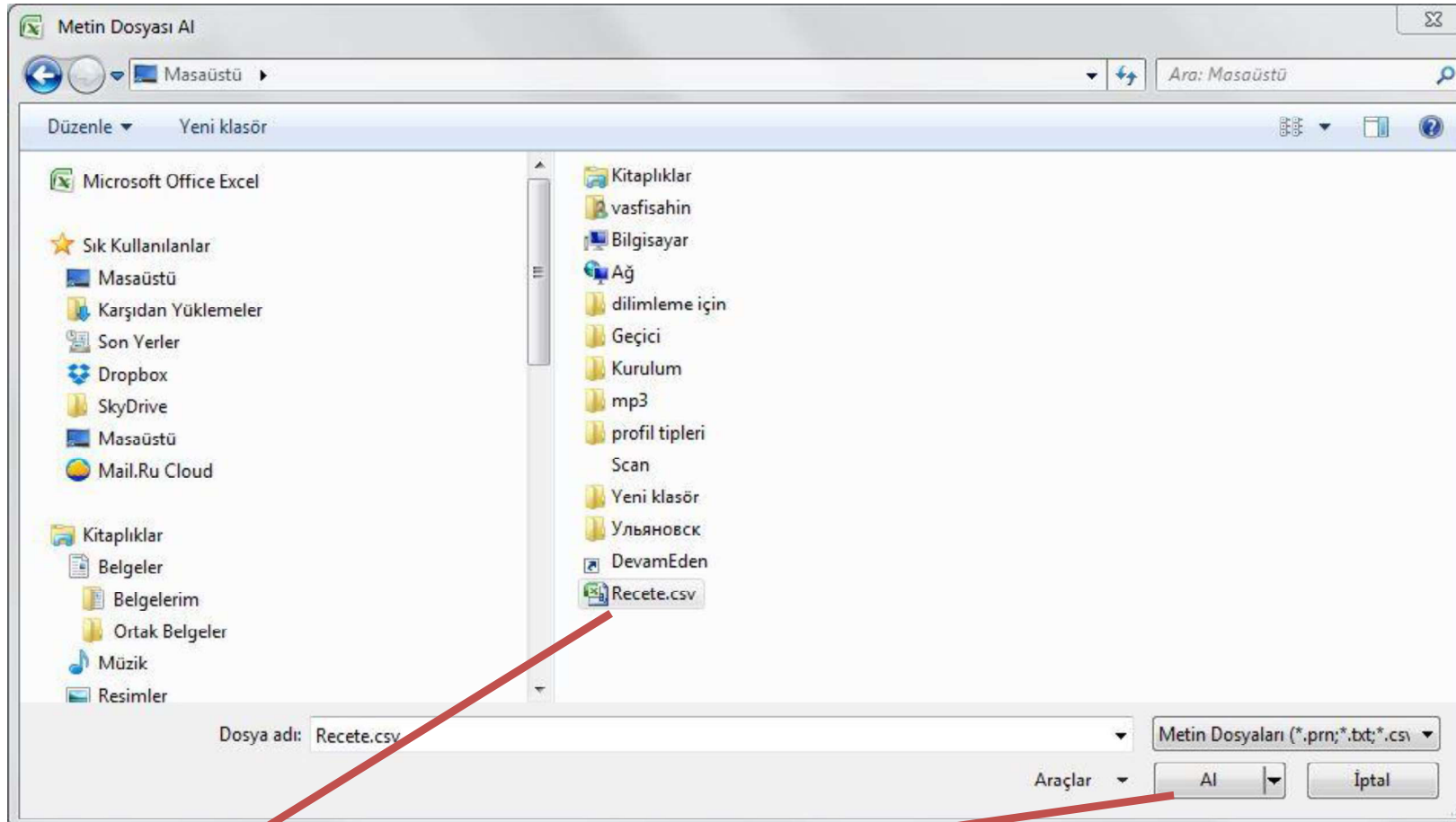

Chose Recete.csv file and push 'Open' key

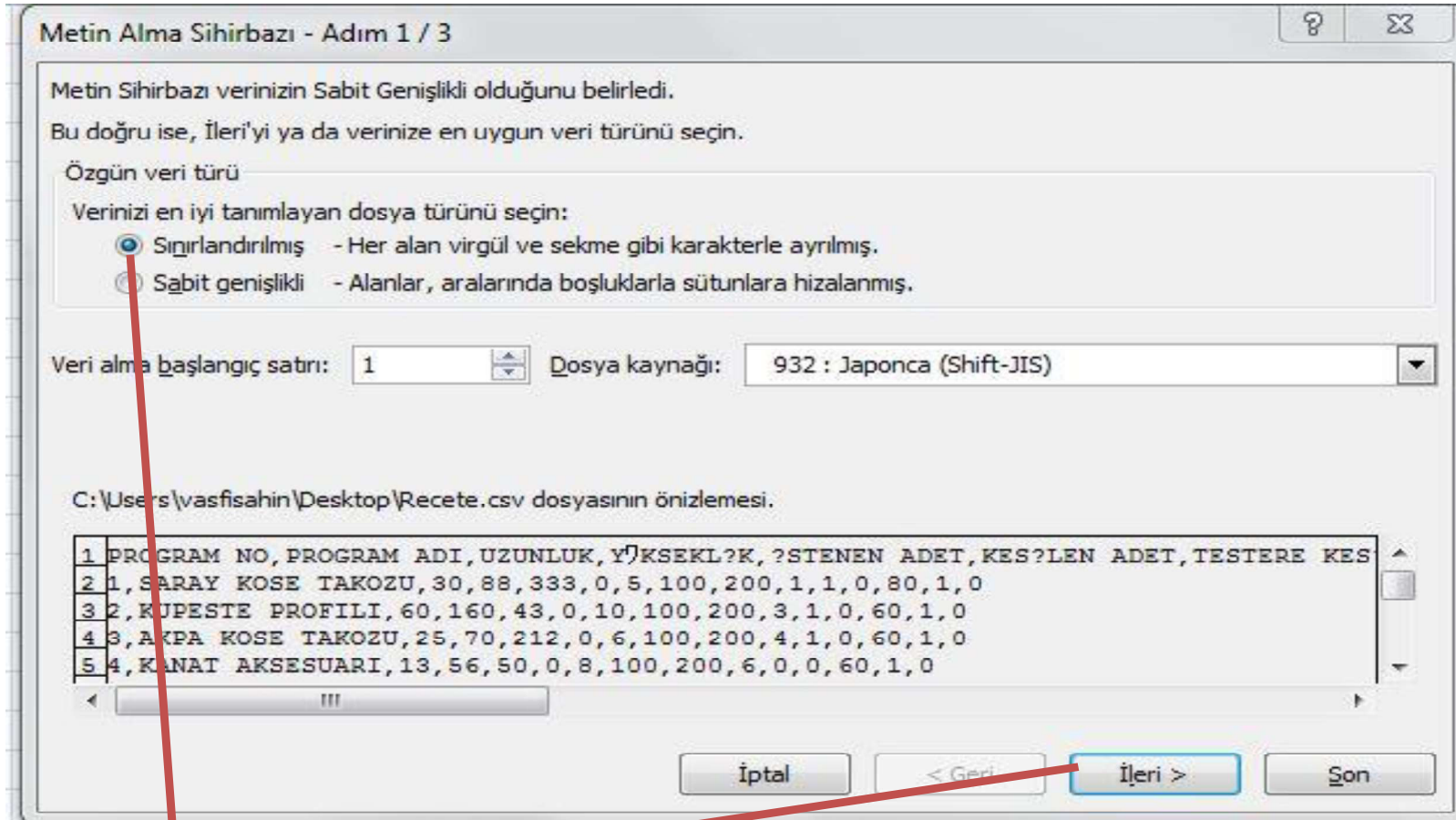

Chose 'Delimited' and push on 'Next' key

Metin Alma Sihirbazı - Adım 2 / 3

Bu ekran verinizin içerdiği ayırıcıları görmenize izin verir. Veri önizleme kutusunda metnin ne şekilde etkilendiğini görebilirsiniz.

Ayırıcılar

Sekme

Noktalı Virgül

Virgül

Boşluk

Diğer:

Ardışık ayırıcıları tek olarak işle

Metin nitelleyicisi:

Veri önizleme

PROGRAM NO	PROGRAM ADI	UZUNLUK	YÜKSEKLİK	STENEN ADET	KESİLEN ADET	TESTERE
1	SARAY KOSE TAKOZU	30	38	333	0	5
2	KUPESTE PROFILI	60	160	43	0	10
3	AKPA KOSE TAKOZU	25	70	212	0	6
4	KANAT AKSESUARI	13	56	50	0	8

İptal < Geri İleri > Son

Chose 'Comma' only and push on 'next' key

Metin Alma Sihirbazı - Adım 3 / 3

Bu ekran her bir sütunu seçmenize ve Veri Biçimi'ni belirlemenize izin verir.

Sütun veri biçimi

Genel
 Metin
 Tarih: GAY
 Sütundan veri alma (atla)

'Genel', sayısal değerleri sayılara, tarih değerlerini tarihlere ve diğer tüm değerleri metne dönüştürür.

Gelişmiş...

Veri Önizleme

Genel	Genel	Genel	Genel	Genel	Genel	Genel
PROGRAM NO	PROGRAM ADI	UZUNLUK	Y/KSEKL?K	?STENEN ADET	KES?LEN ADET	TESTERE
1	SARAY KOSE TAKOZU	30	88	333	0	5
2	KUPESTE PROFILI	60	160	43	0	10
3	AKPA KOSE TAKOZU	25	70	212	0	6
4	KANAT AKSESUARI	13	56	50	0	8

İptal < Geri İleri > Son

Chose 'General' and push on 'Finish' key

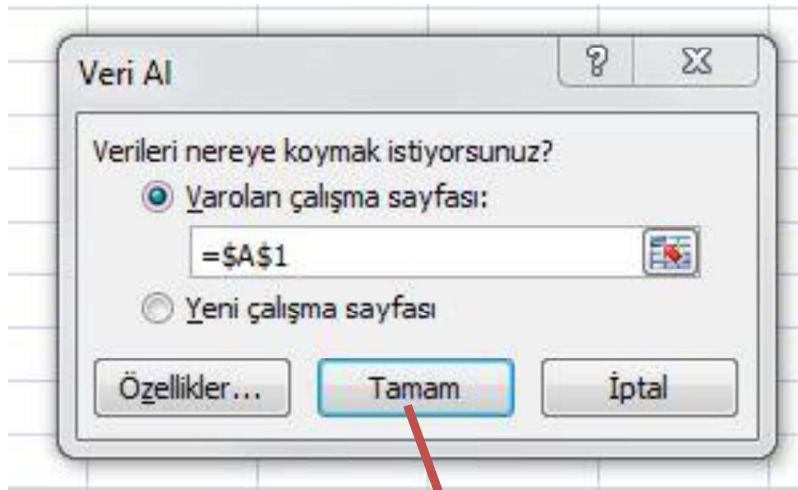

Push on 'OK' key

PROGRAM NO	PROGRAM ADI	UZUNLUK	YÜKSEKLİK	İSTENEN ADET	KESİLEN ADET	TESTERE KESİM HIZI	MALZEME İLERİ TAĞIMA HIZI	MALZEME GERİ TAĞIMA HIZI	PROGRAM ATIM SÜRESİ	TABLA HAREKETİ	TESTERE OFSET	SENSÖR OFSET	AKTIF	YEDEK
1	SARAY KOSE TAKOZU	30	88	333	0	5	100	200	1	1	0	80	1	0
2	KUPESTE PROFİLİ	60	160	43	0	10	100	200	3	1	0	60	1	0
3	AKPA KOSE TAKOZU	25	70	212	0	6	100	200	4	1	0	60	1	0
4	KANAT AKSESUARI	13	56	50	0	8	100	200	6	0	0	60	1	0
5	MOBİLYA AKSESUARI	5	60	500	0	30	100	200	1	1	0	80	1	0

Make the necessary changes on these values

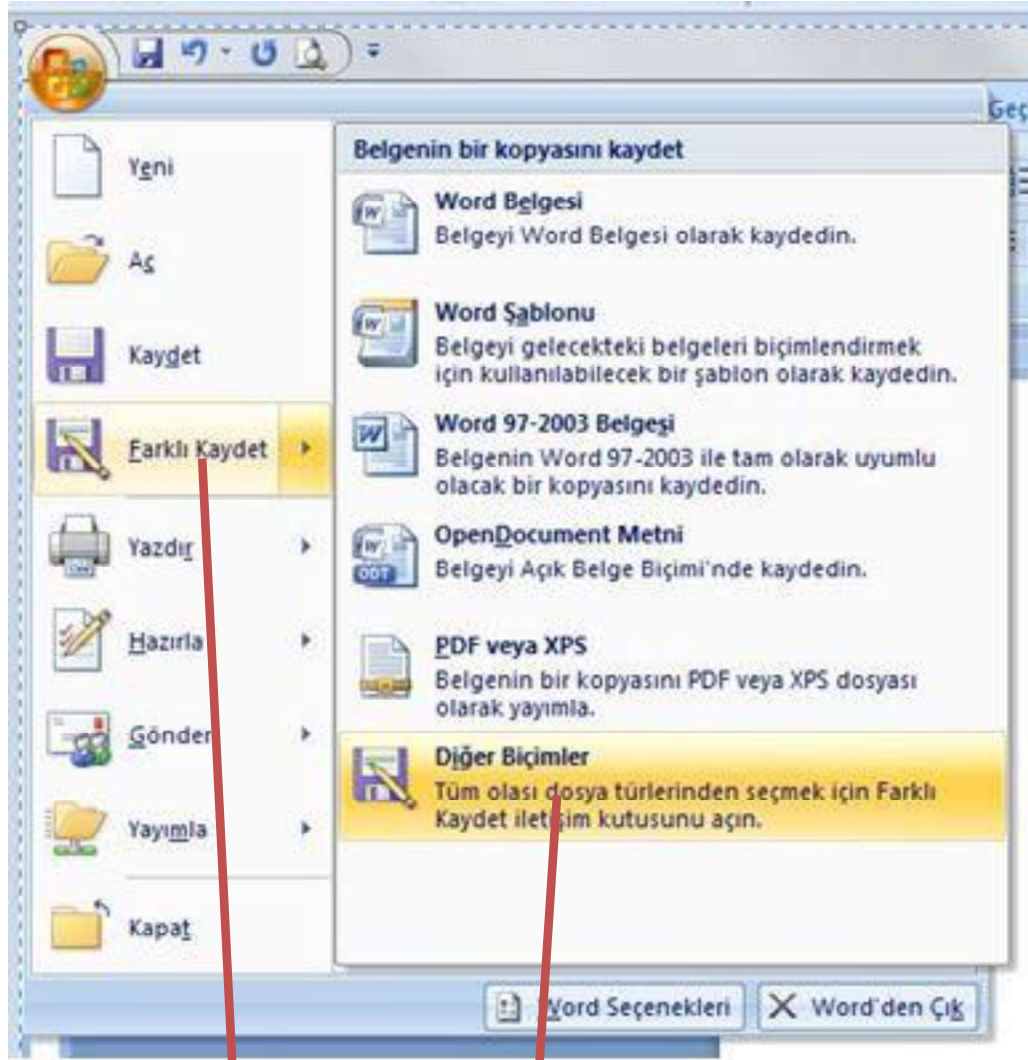

Chose on 'Save As' and 'other options' keys

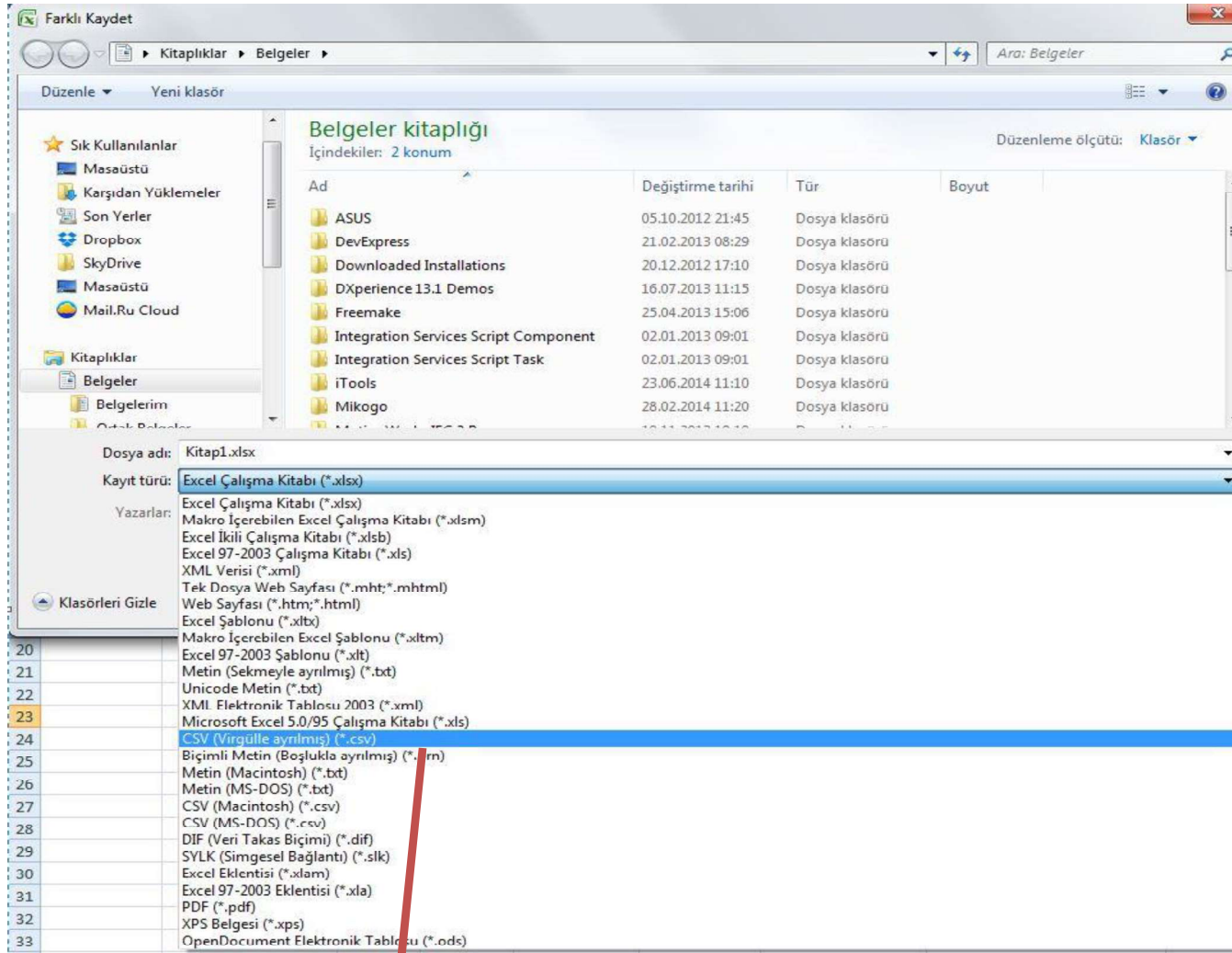

Chose on CSV (Comma Delimited)(*.csv) bar and define the place where you will save the file and push on 'Save' key. Than you will copy this file to the computer of the Machine. The name of the file must be same as 'Recete.csv' exactly.

7.2.6 Uploading The Creating File

7.2.6.1 Copy edited cutting list (**Recete.csv**) to USB memory

7.2.6.2 Cutting list should be copied directly under the name of removable device not under a folder.

7.2.6.3 Turn on machine

7.2.6.4 Insert USB memory into machine.

7.2.6.5 Open  screen

7.2.6.6 Press on  button on the screen

7.2.6.7 Program starts over. Open the program in desired language

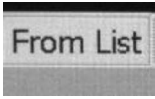
7.2.6.8 Open  screen. Cutting list appears on the screen.

7.2.7 Single Cutting Operation

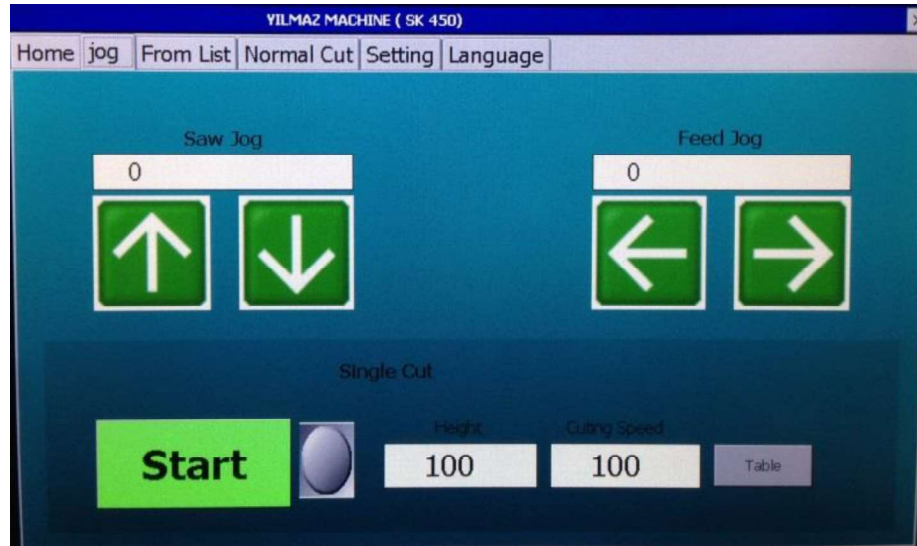

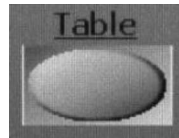

FIGURE- 21

7.2.7.1 Press  tab (FIGURE 21)

7.2.7.2 Enter the height of part to be cut in  section

7.2.7.3 Enter cutting speed in  section

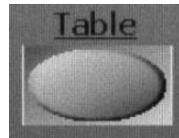

7.2.7.4 Press on  button to activate or deactivate the operation of table..

7.2.7.5 Place the part to be cut on the machine.

7.2.7.6 Squeeze the clamps

7.2.7.7 Close the covers of machine

7.2.7.8 Press on Start button.

7.2.7.9 Saw cuts the parts only once and returns back to its rest position. Cutting process does not continue as in the case of other operation modes.

7.2.8 Machine Settings

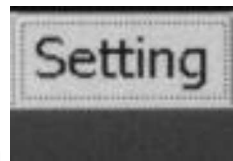

7.2.8.1 Press on  tab

7.2.8.2 The left hand side of logo contains the settings that operator can adjust. (FIGURE 22)

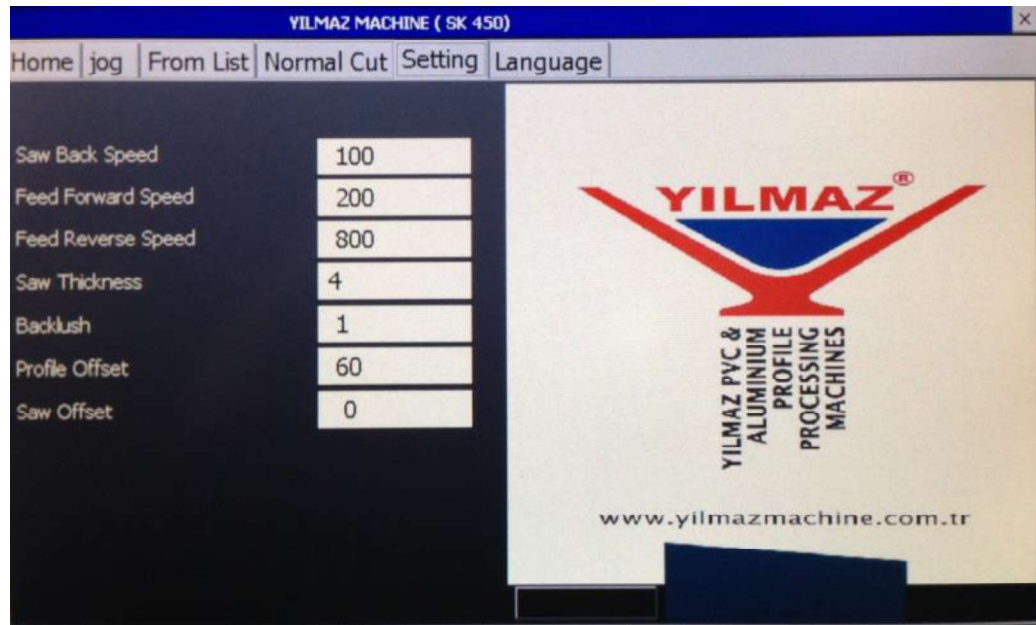

FIGURE 22

7.2.8.3 Cutting speed of saw in normal operation mode is entered in



section

7.2.8.4 The return speed of saw after operation is entered in section.





7.2.8.5 The speed of material to be cut is entered in



section.

7.2.8.6 The speed of empty table while moving to load the material is entered in  section.

7.2.8.7 The offset distance at each time conveyor moves back is entered in  section.

7.2.8.8 Offset distance at which clamp is located from the end of the part is entered in  section.

7.2.8.9 Machine holds a saw whose diameter is 450 mm. Saws with smaller diameter can be mounted. In case a saw having smaller diameter is mounted, half of the diameter difference should be entered in as offset value in  screen. **(For instance replaced saw has a diameter of 400 mm; 25 mm should be entered as offset value.)**

7.2.9 Service and Operator Settings

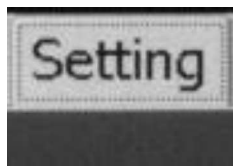

7.2.9.1 Press on  section (FIGURE 22)

7.2.9.2 Press on  button in settings screen (FIGURE 22).

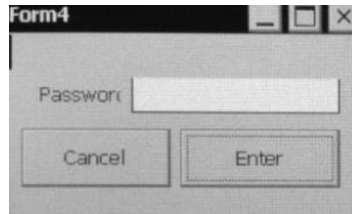

7.2.9.3 Password screen appears

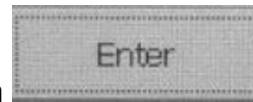

7.2.9.4 Enter (...) as password and press on button.

7.2.9.5 Yılmaz logo disappears from screen and factory settings screen appears.

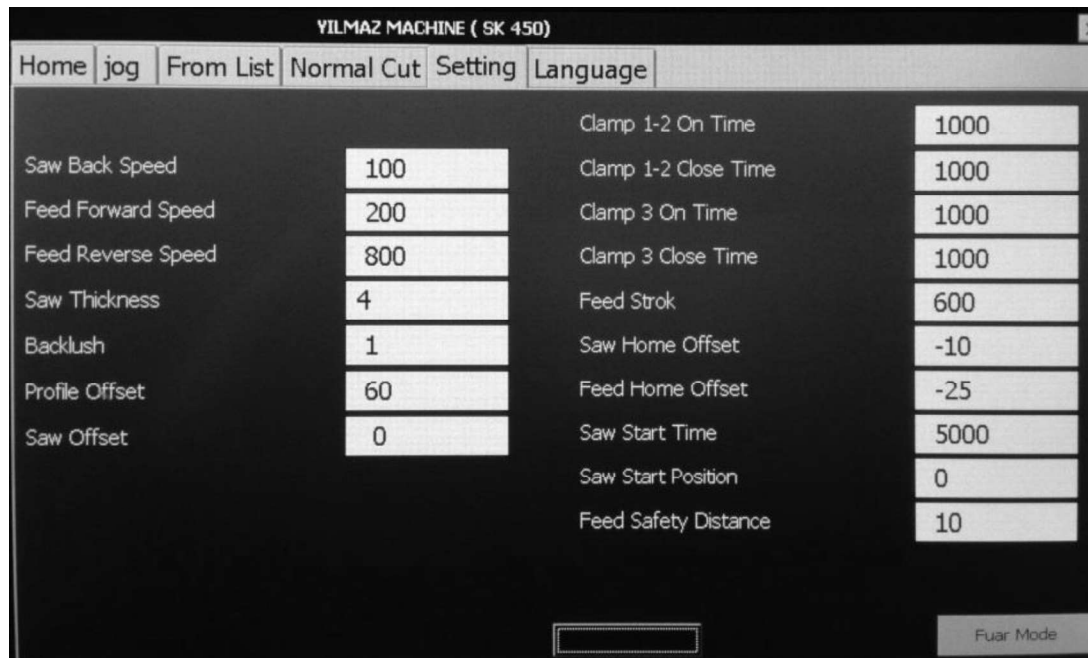

RESİM- 23

- 7.2.9.6 Before starting to feed the profile, the waiting time of open clamps, which are on the left hand side, is entered in **Clamp 1-2 On Time** section. For example after “Open the clamps” order is raised, program waits for the value entered in this section, and starts feeding part when time expires.
- 7.2.9.7 Before completing to feed the profile, the waiting time of closed clamps, which are on the left hand side, is entered in **Clamp 1-2 Close Time** section. For example after “Close the clamps” order is raised, program waits for the value entered in this section, and starts cutting when time expires.
- 7.2.9.8 The waiting time of moving clamp in open position, before moving to take the material, is entered in **Clamp 3 On Time** section. For example after “Open the clamps” order is raised, waits for the value entered in this section, and moves to head when time expires
- 7.2.9.9 The waiting time of moving clamp in closed position, before feeding the material, is entered in **Clamp 3 Close Time** section. For example after “Close the clamps” order is raised, waits for the value entered in this section, and feeds the parts when time expires.
- 7.2.9.10 The maximum translational distance of conveyor is entered in **Feed Strok** section.

7.2.9.11 While machine is in operation and profile is feeding, the safety margin at which moving table gets closer to stationary table is entered in **Feed Safety Distance** section.

7.2.9.12 After reference determination, the offset value, to set the saw 5 mm below the table, is entered in **Saw Home Offset** section.

7.2.9.13 After reference determination, the offset value to have 10 mm distance between moving and stationary tables is entered in **Feed Home Offset** section.

7.2.9.14 The waiting time for saw to achieve the required speed, after starting the machine and before starting cutting, is entered in **Saw Start Time** section. For example after turning on the machine, engine of the saw starts and begin cutting when waiting time expires.

8. MAINTENANCE, SERVICE AND REPAIR

8.1 Maintenance

8.1.1 Cut the electric and pneumatic power connections of the machine.

8.1.2 Clean all surfaces of the machine from burs, chips and foreign substances. If the machine will not be used for a long time, lubricate undyed parts with oil that prevents rusting.

8.1.3 When cleaning the machine, do not use materials that may damage the dye.

- 8.1.4 Control cutting tools against corrosion, distortion and fractions. If cutting tools are damaged, change them..
- 8.1.5 Before using cutting tool, operate the machine out of gear and control whether it is inserted correctly, it is without flexure and it is inserted appropriately. Do not use cutting tools that are damaged or lost its functionality.
- 8.1.6 If the sawteeth are blunted, change immediately with a new / sharpened saw.
- 8.1.7 Sharpen with proper sharpening machines by taking the angular value of the saw into consideration.

8.2 Lubrication of the moving unit

- 8.2.1 Perfect lubrication of the threaded rods is important not only for achieving calculated service life of the rods but for silent working of the machine, and its effect on heat rise during working and unloaded torque as well.



THREADED RODS SHOULD BE LUBRICATED ONCE A DAY BY PULLING LUBRICATION ARM 2 TIMES. (FIGURE 24)

FIGURE- 24

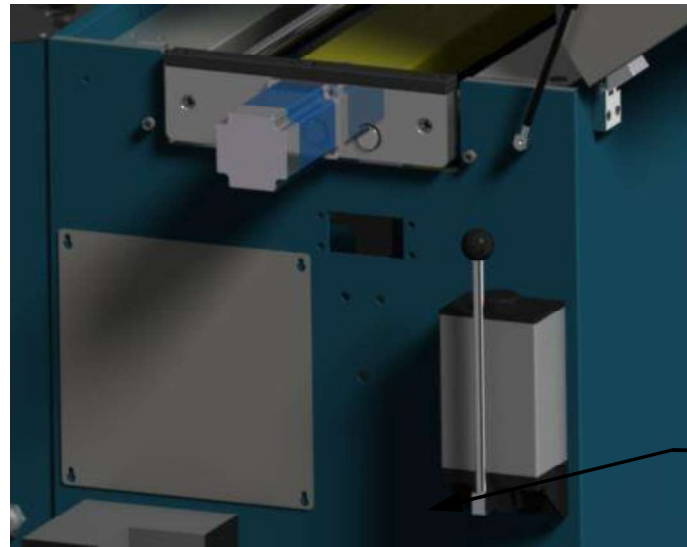

Lubrication Arm

8.2.2 By using the LUBRICATION UNIT lubricate the threaded rods. **For lubricant please refer to Figure 1.**

	MOBIL	BP	CASTROL	PETROL OFISI	SHELL	ELF
Pneumatic System	MOBIL DTE LIGHT	BP ENERGOL HLP 10	-----	SPINDURA	TELLUS C 10	
Threaded Spindle	VACTRA OL HEAVY MOBILGEAR 627	ENERGOL RC 100 ENERGOL GR-XP 100	HYSPIIN 100 HYSPIIN SP 100	-----	-----	POLYTEUS 100 MOGUA 100
Metalworking fluid	MOBILMET 404	-----	ALUSOL M - FX	-----	-----	-----

FIGURE-1

8.2.3 Usage of the coolant fluid during cutting is very easy it is sprayed to the saw surface during all cutting phase. Coolant application to saw surface ensures surface smoothness of the cut material, prevents length distortions due to heating, extends the service life of saw. For this reason special attention should be paid on coolant application.



WHEN COOLING WATER FOR CUTTING RUNS OUT OF, ALARM APPEARS ON THE SCREEN. POUR OIL IN THE SECTION SHOWN IN FIGURE. (FIGURE 25)

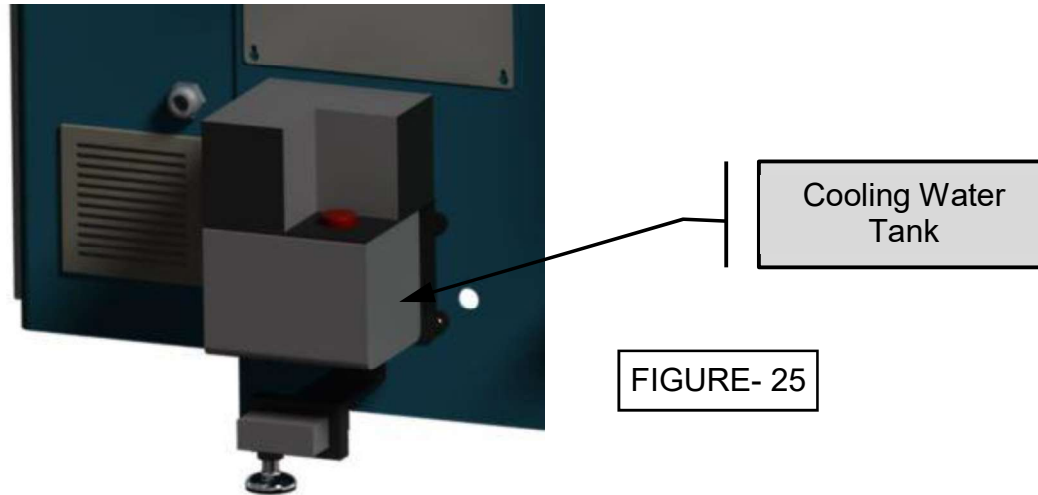

FIGURE- 25

8.3 Changing the cutting tool

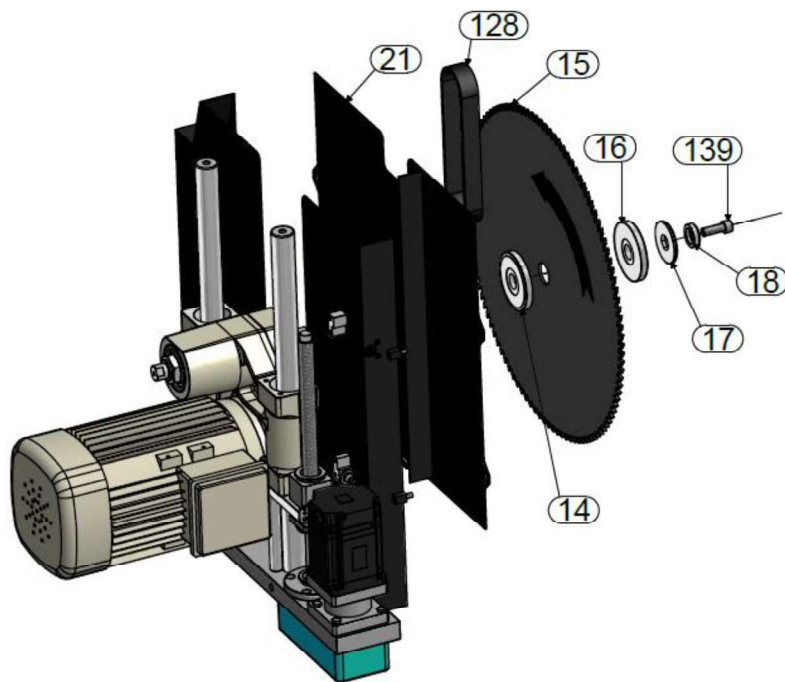
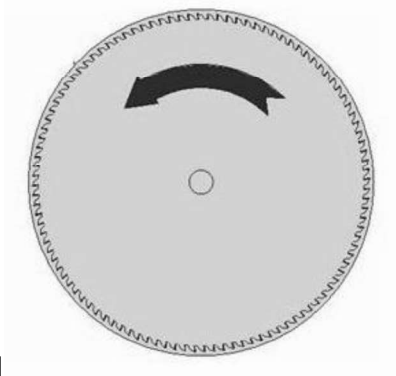

FIGURE- 26





8.3.1 Use protective gloves when replacing Saw

8.3.2 Cut the electric connection of the machine.

8.3.3 Take the four nuts out by turning the nuts on the protective cover of the saw by using a suitable key and take out the protective cover.(FIGURE 5 NO.21)

8.3.4 Take the M10 screw (FIGURE 6 NO.139) outside by rotating in the direction of counter clockwise with 8mm Allen switch. (Hold with 17 two-edged switch from the side in the saw axle of which switch edge is opened)

8.3.5 Remove the connection parts of cutting set in the right order.. (FIGURE 6 NO.16 /17 / 18)

8.3.6 Remove the saw carefully

8.3.7 Mount the saw by being sure that the rotation direction onto the axle is true.(FIGURE 5 NO.40)

8.3.8 Replace all removed parts in the same order.

8.3.9 By holding the M10 Allen screw by 8mm Allen switch and the saw axle simultaneously by 17 switches tighten in the direction of clockwise.

8.3.10 The saw selection should be made proper to EN 847-1 Standard.

8.4 Replacing the Motor Belt:

8.4.1 Remove the bolt that fastens the belt housing cover and remove the cover.

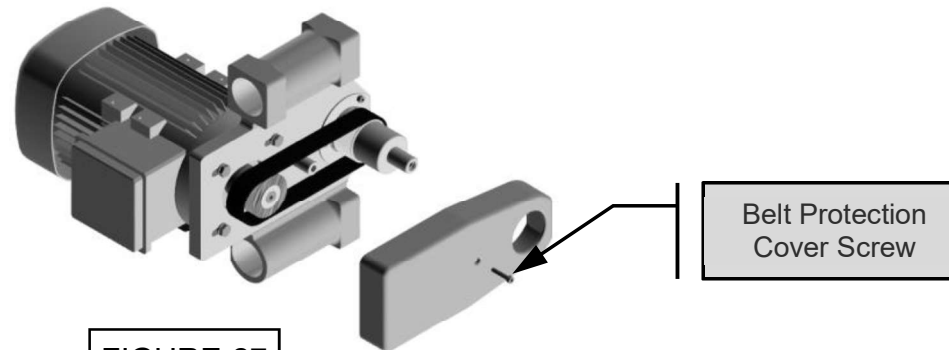

FIGURE-27

8.4.2 Loosen the motor mounting screws by using a wrench

8.4.3 After the motor mounting screws are loosened, tension of the belt will be reduced by moving the motor forwards or backwards and then the belt will be removed.

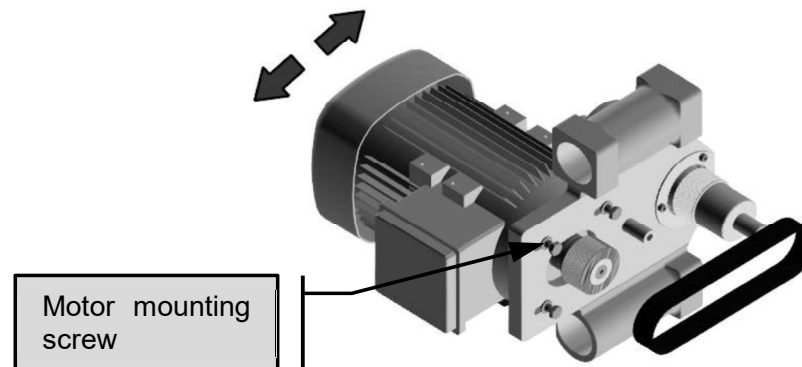
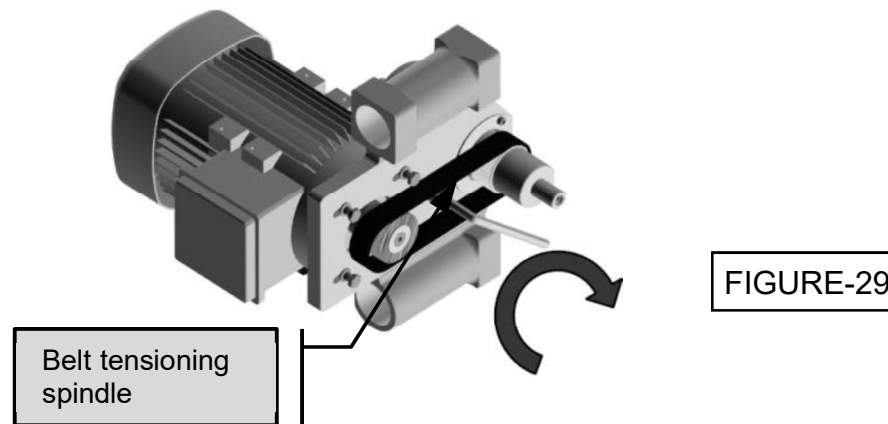

FIGURE-28

- 8.4.4 Install a new belt in place of one that you have removed.
- 8.4.5 After installing the new belt, tighten the tensioning spindle by turning it clockwise by using a no. 8 allen wrench and tension the belt.
- 8.4.6 Retighten the motor screws after tensioning the belt (FIGURE 25).
- 8.4.7 Finally, complete belt replacement operation by fastening the belt housing cover



8.5 Zincir Dişliyi Değişirme :

8.5.1 Remove bolts on chain housing, and take the container out. (FIGURE 30)

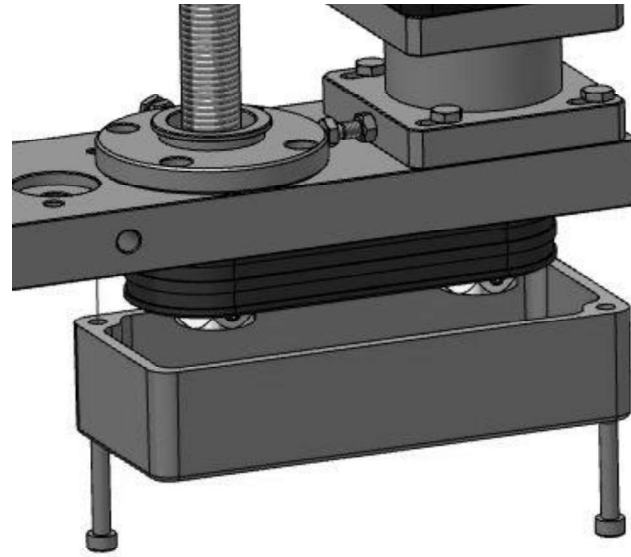

FIGURE-30

8.5.2 Loosen chain tension, and engine mount bolts. Take the engine in the indicated direction. Chain is loosened. Free chain from teeth and take out by pulling it downwards. (FIGURE 31)

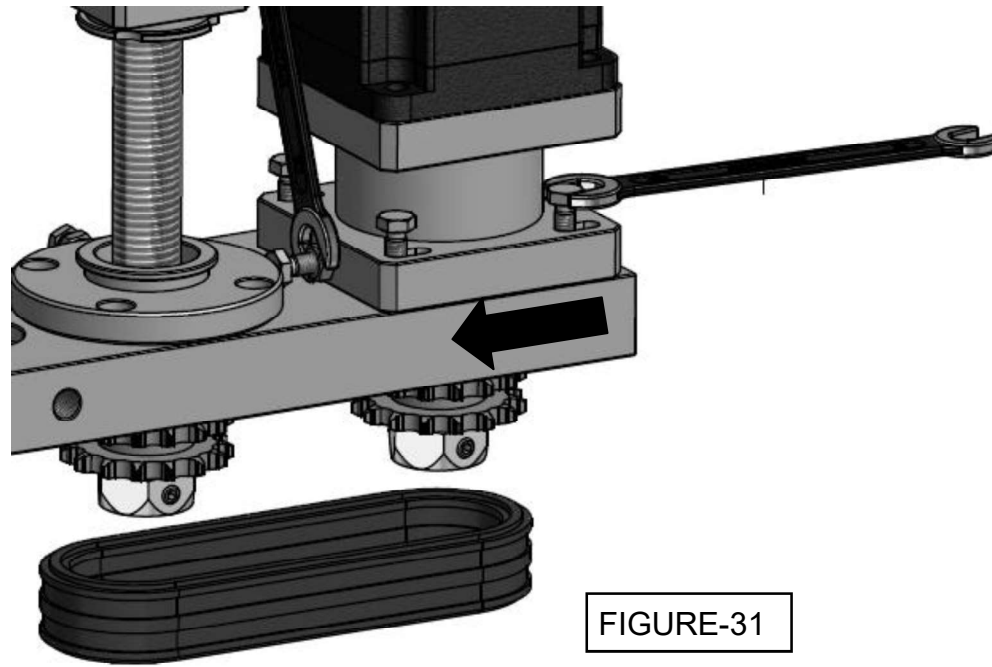
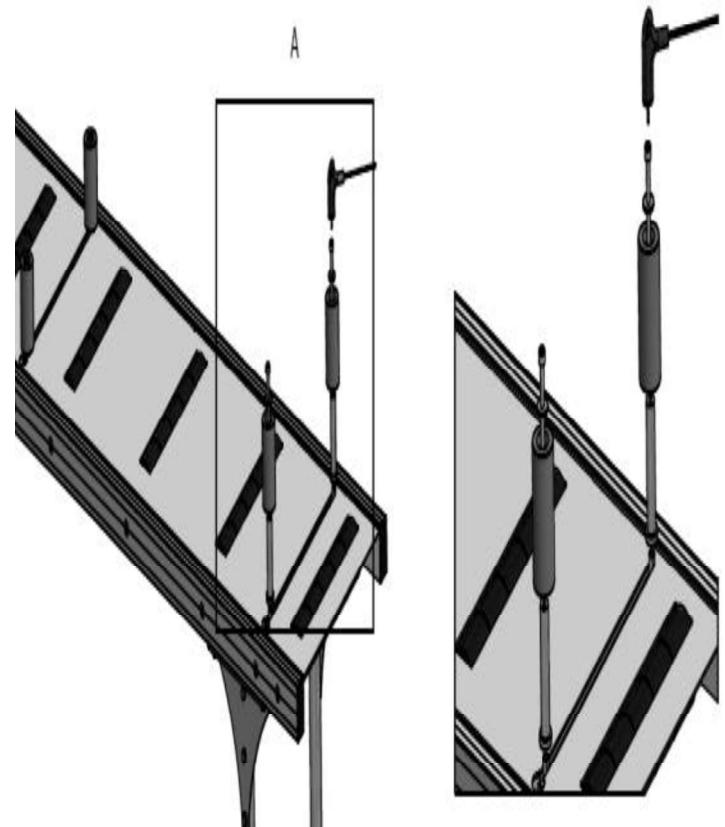

FIGURE-31

-
- 8.5.3 Insert new chain instead of removed one
 - 8.5.4 After mounting new chain, follow the reverse procedure given above, stretch the chain, and tighten the tensile bolt with the help of key.
 - 8.5.5 After stretching the chain, tighten the engine mount bolts.
 - 8.5.6 At last mount the chain housing. Chain changing operation is completed.

8.6 Adjust the air pressure (pneumatic systems)

- 8.3.1 Pull up pressure adjustment valve. Set adjustment valve to the desired value on manometer by turning it clockwise or counter clockwise. Then lock the valve by pressing it down.
- 8.3.2 Set the air pressure between 6 and 8 BAR. If air pressure drops below the stated values, accessories operating with pneumatic power do not work.
- 8.3.3 Conditioner unit accumulates the water in the air in the collection container so that it won't damage pneumatic components. At the end of the working day, empty the accumulated water by opening water discharge valve under the collection container
- 8.3.4 In order to put oil to the oil tank, remove the reservoir by turning. Oils recommended by the manufacturer are; ; TELLUS C10 / BP ENERGOL HLP 10 / MOBIL DTE LIGHT / PETROL OFISI SPINDURA 10.



9. NOISY EMISSION VALUES

Material	Aluminyum	LwA	92 dB (Measured Value)
Lenght	1220 mm.	LpA	93 dB (Average Sound Pressure Value)
Width	70 mm.	K	2 dB (Uncertainty in the Measurements)
Height	60 mm.		
<p>The values given for the noise are the emission level and it does not show that it is in the safe working level. A connection between emission and exposure levels is available, however it is not used confidently for the determination whether these more advanced precautions are necessary or not. The factors that affect the real level of exposure, affecting the working power, are residence time, features of working place, in other words other noise resources, actions on other side and the number of the machines. Furthermore, the exposure level given permission can change from country to country. This informing, however, provides the machine user to evaluate the hazard and risks well.</p>			
Machine Characteristic Information		Saw Characteristic Information	
Testere Dönüş Hızı	3000 dev / dak	Saw Size	450 mm
Motor Gücü	2.2 kW	Saw Thickness	4 mm
Nominal Gerilim	400 V	Saw Shaft Thickness	3.2 mm
		Saw Progress Speed	70 m / sn. (Aluminyum material)

10. WARRANTY CONDITIONS

YILMAZ Machine Industry and Trade Limited Company, guarantees that all machines have been tested and conform to the international standards.

The guarantee is valid 24 months from despatch date and does not cover the electrical parts of the machine.

During this period:

- Any repair and replacement effected at our workshop is completely free of charge (only transport costs are at customer's charge).
- For repair and replacement effected by our technician at the customer's site, we will invoice only the travel and lodging costs for our technician.

The guarantee does not cover damages caused by:

- not respect of the rules indicated in the manual instruction book
- not correct voltage
- improper use or use not in accordance with what the Machine has been designed for
- use of non original tooling
- programming errors
- lack of cleaning and of ordinary maintenance by the customer
- transport or displacement (even inside the workshop)
- natural events (lightings, fires, floods)

The warranty does not cover, in any case, damages caused by the malfunction of the Machine

ELECTRIC&PNEUMATIC DIAGRAM

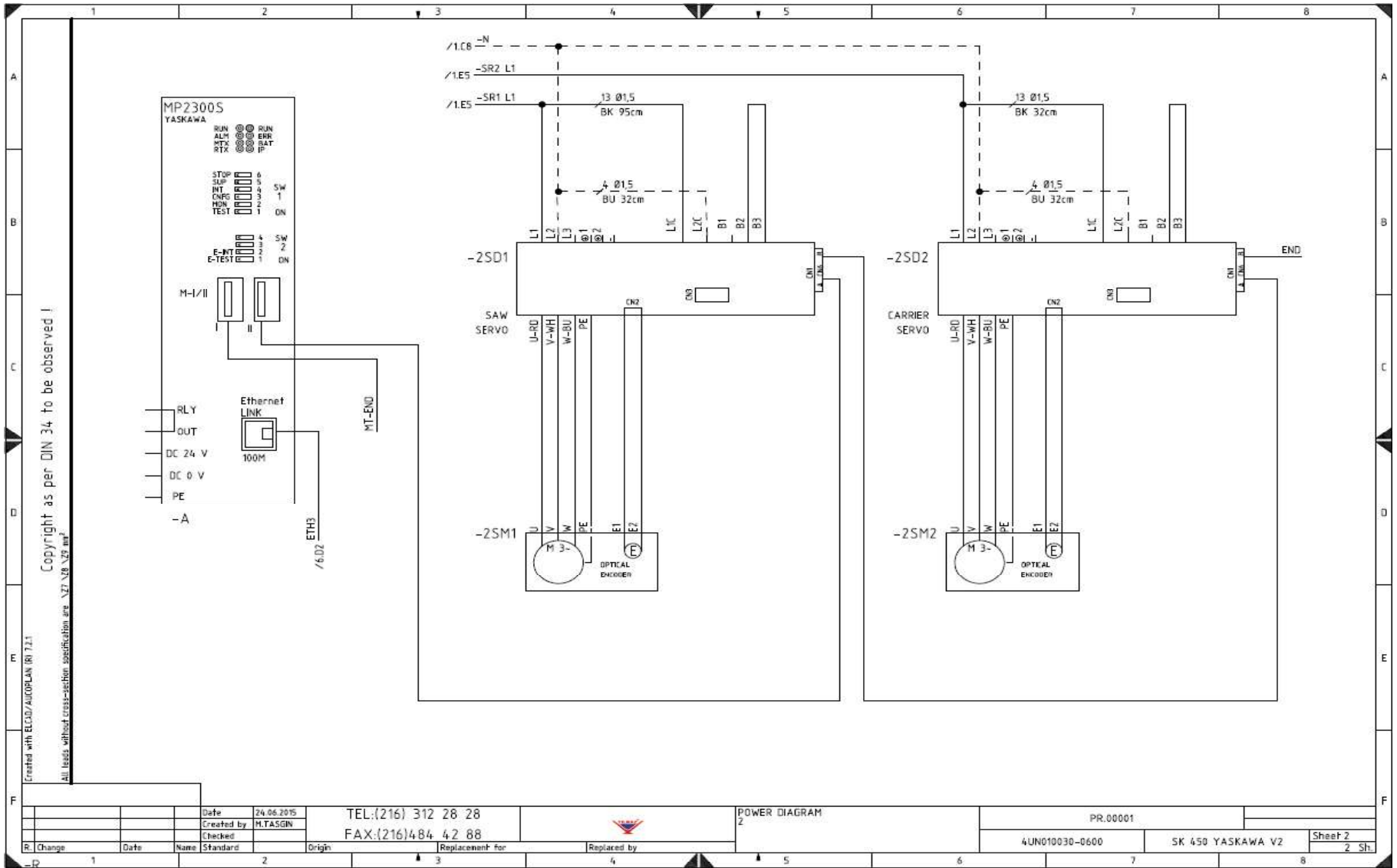

Copyright as per DIN 34 to be observed !

Created with ELCAD/AUCOPLAN (R) 7.2.1

All leads without cross-section specification are NZ 1.8 / 25 mm²

Date		24.06.2015		TEL: (216) 312 28 28		POWER DIAGRAM		PR.00001	
Created by		M.TASGIN		FAX: (216) 484 42 88		2		4UN010030-0600	
Checked								SK 450 YASKAWA V2	
R. Change		Date		Name		Standard		Origin	
1								2 Sh.	

ELECTRICAL DIAGRAM SHEET 2

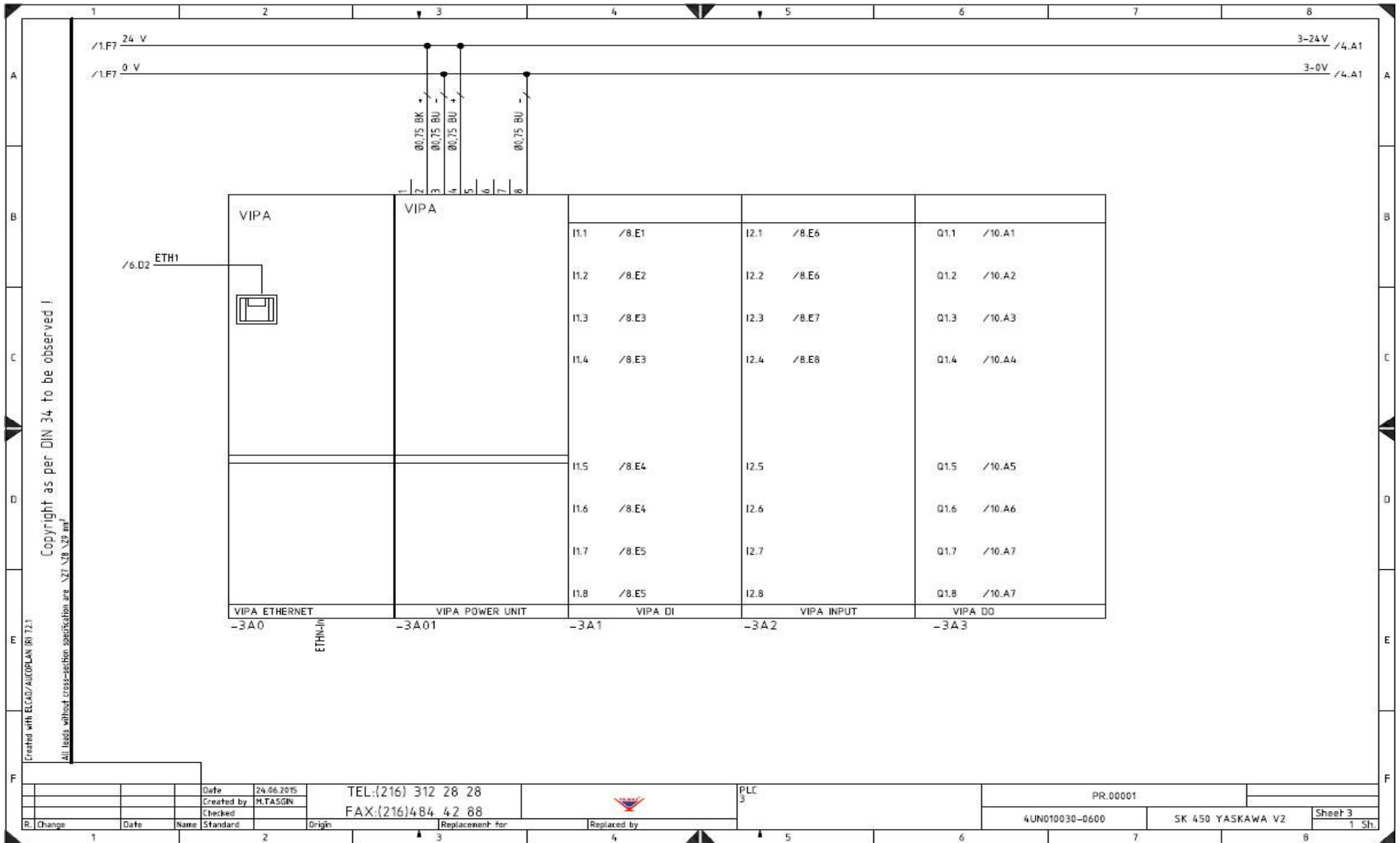

ELECTRICAL DIAGRAM SHEET 3

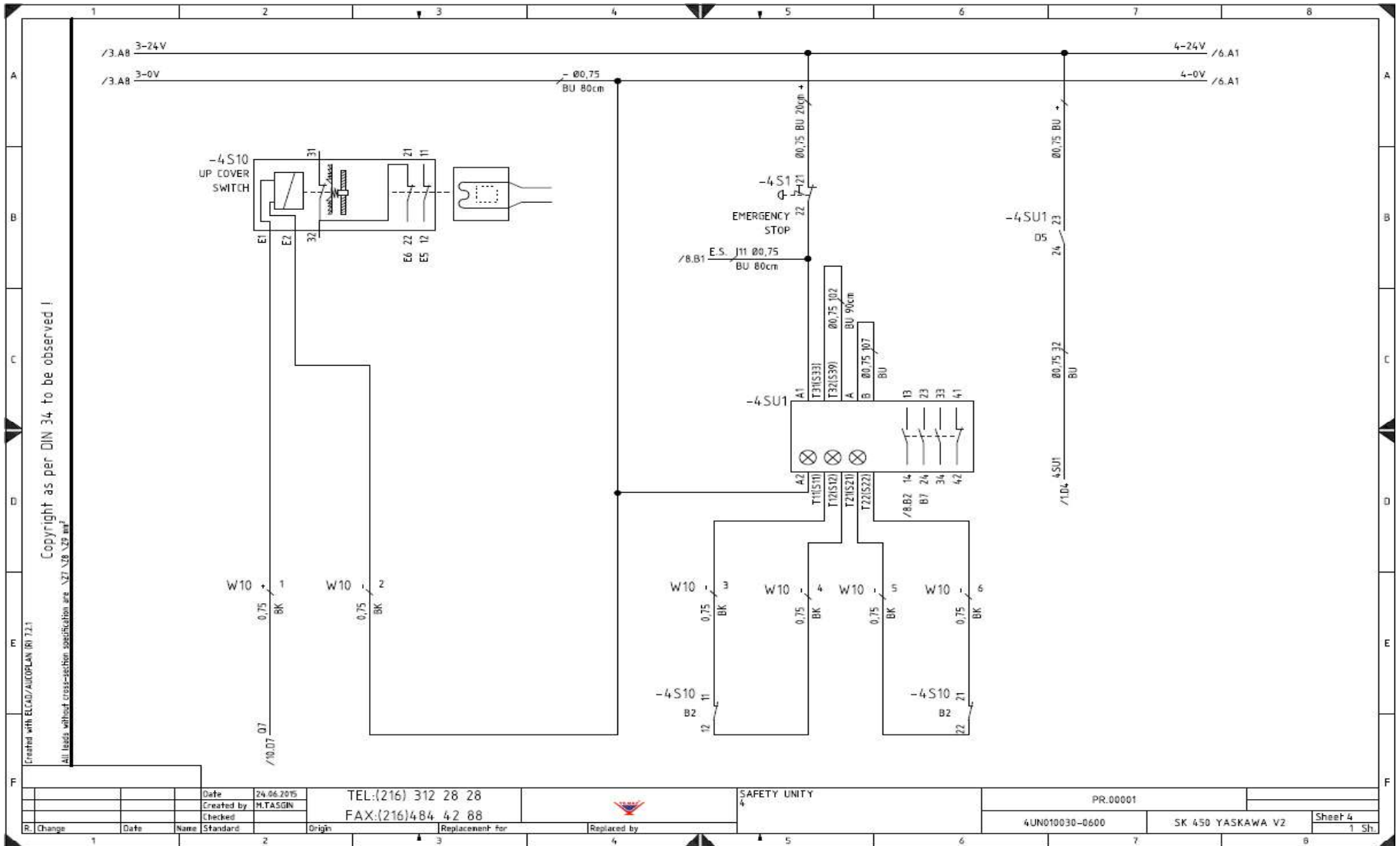

ELECTRICAL DIAGRAM SHEET 4

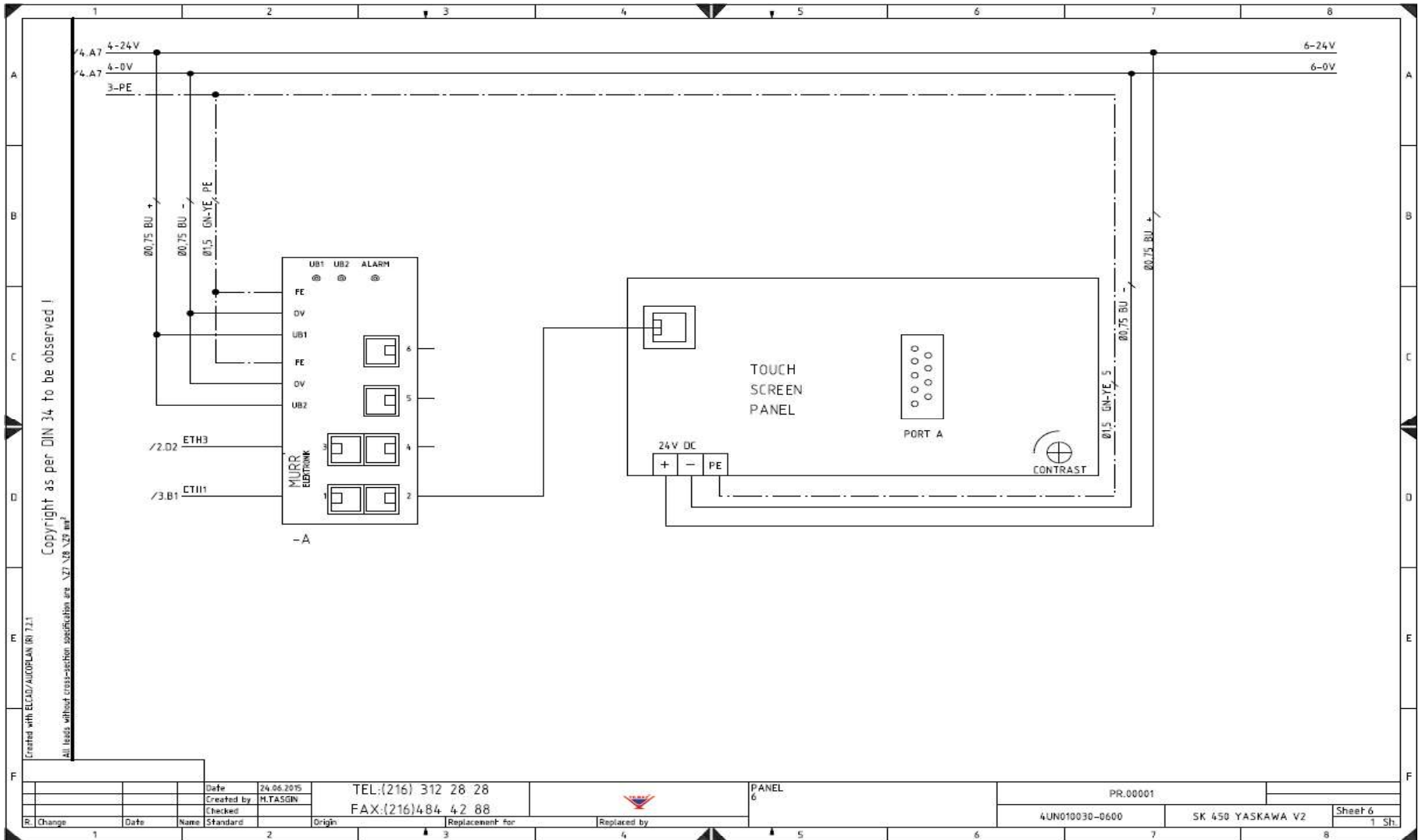

ELECTRICAL DIAGRAM SHEET 5

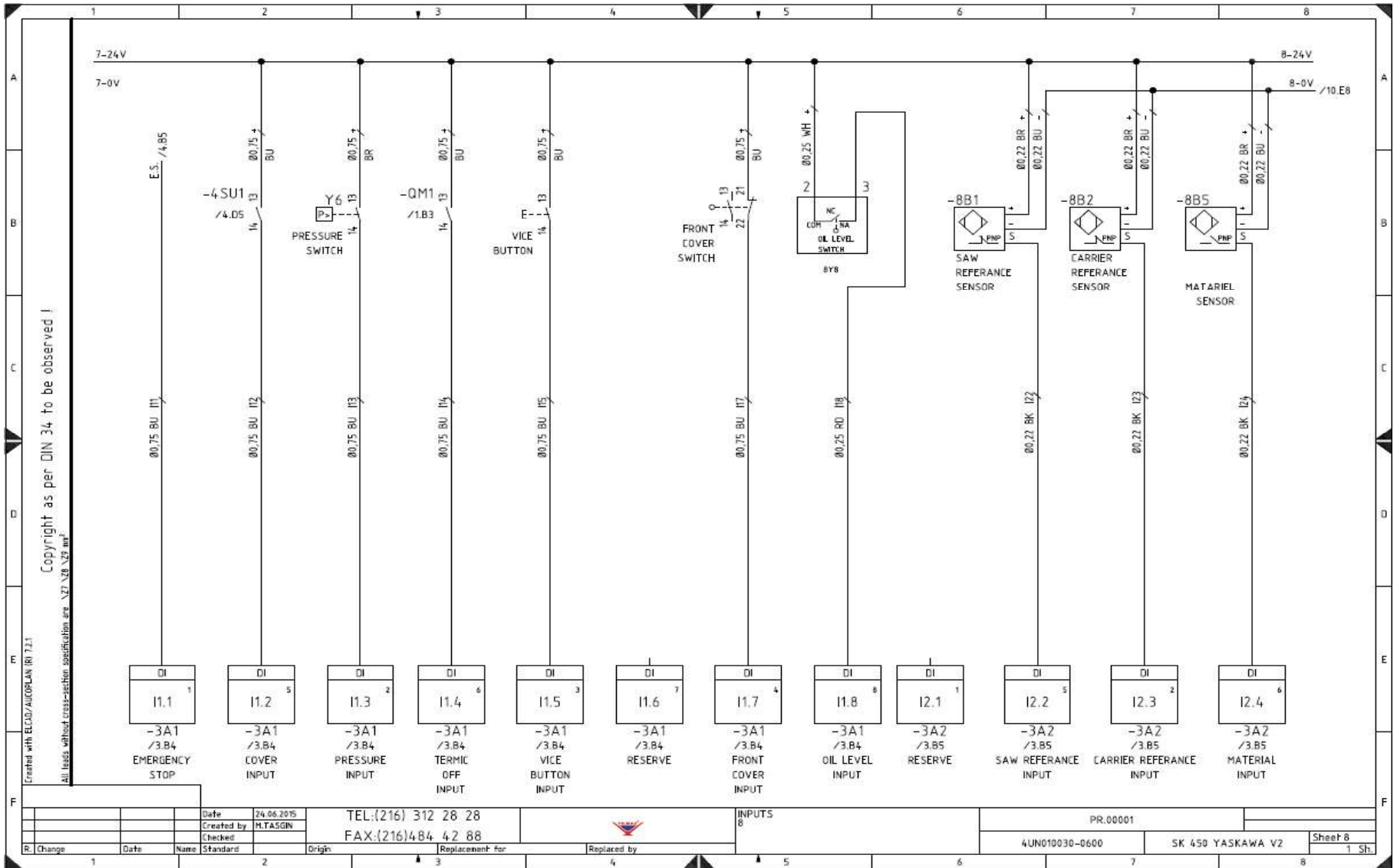

ELECTRICAL DIAGRAM SHEET 6

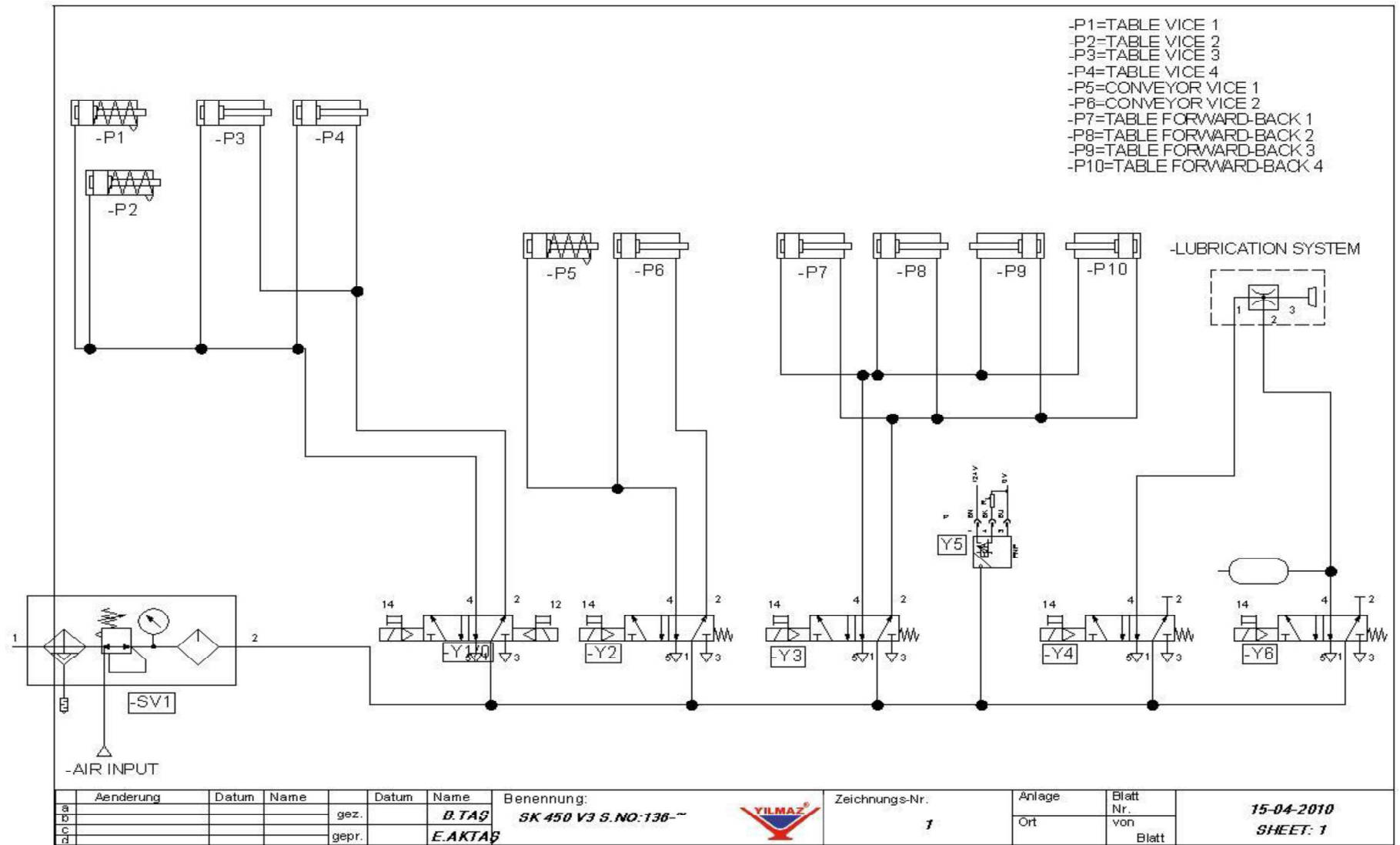

PNEUMATIC DIAGRAM