



## Conveyor Installation Instructions

Thank you for purchasing an Australian made Luna Roller Conveyor.  
For customer service or spare parts contact your nearest Luna Machinery representative.  
There is a Luna representative in every capital city of Australia and New Zealand.

### Conveyor Components

Picture	Description	QTY
	Conveyor Extrusion	2
	End Cap	2
	M10 x 20mm Bolt	12
	M10 x Nut	12
	M10 Spring Washer	12
	Rollers	3.0Metre(10),4.5Metre(13)
	Roller Holders	3.0Metre(20),4.5Metre(26)
	Self Tapping Screws	3.0Metre(20),4.5Metre(26)
	Mounting Bracket	1
	Conveyor Bracket	2

## Installation Instructions

Step 1 – Remove the dome/acorn nuts and slip the conveyor over the threaded rods on the stand. Re-fit the dome/acorn nuts and tighten. See picture 1 and 2.

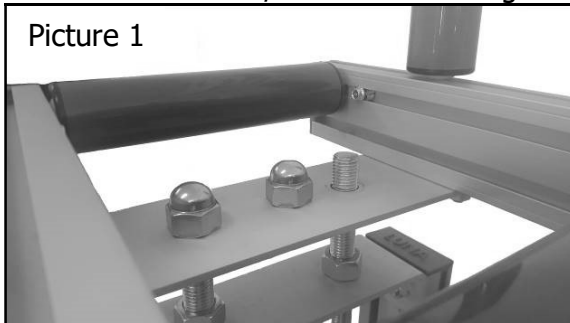

Picture 1

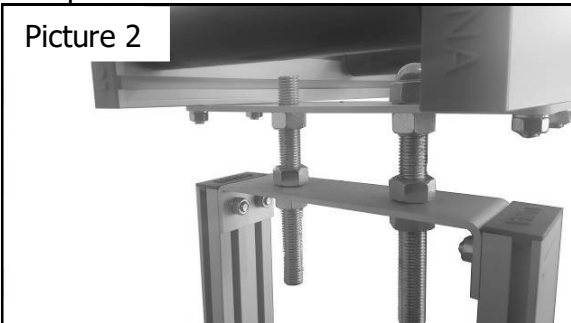

Picture 2

Step 2 – Attach the conveyor to the saw as per picture 3. If fitting to a Luna saw, mounting holes and bolts should already be provided. If mounting to another machine drill mounting holes as per picture 4 and attach using M8, M10 or screws as required.

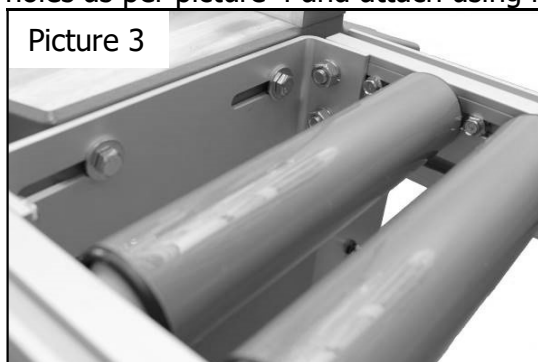

Picture 3

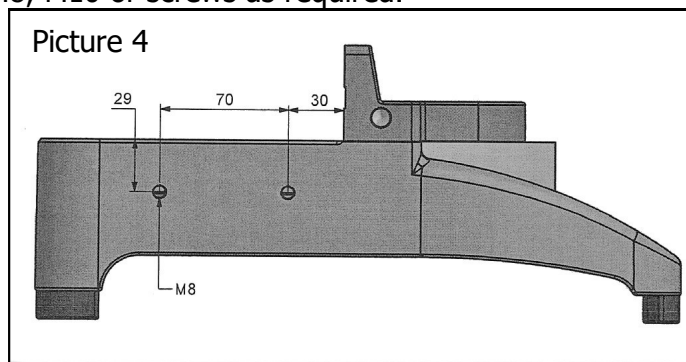

Picture 4

Step 3 – Using the the M20 nuts level the conveyor to the height of your saw table. Check both ends and tighten when level.



Picture 5



Picture 6